

**T.C.
ISTANBUL AYDIN UNIVERSITY
INSTITUTE OF GRADUATE STUDIES**



**DESIGN OF A FIBER TO THE HOME FTTH ACCESS NETWORK IN
SOMALIA USING GPON TECHNOLOGY**

**MASTERS THESIS
ABDIKANI SAID MUSE**

**Department of Electrical and Electronics Engineering
Electrical and Electronics Engineering Program**

June, 2021

T.C.
ISTANBUL AYDIN UNIVERSITY
INSTITUTE OF GRADUATE STUDIES



**DESIGN OF A FIBER TO THE HOME FTTH ACCESS NETWORK IN
SOMALIA USING GPON TECHNOLOGY**

MASTERS THESIS
ABDIKANI SAID MUSE
(Y1913.300015)

Department of Electrical and Electronics Engineering
Electrical and Electronics Engineering Program

Thesis Advisor: Assist. Prof. Dr. Eylem Gulce ÇOKER

June, 2021

ONAY FORMU

DECLARATION

I hereby declare with respect that the study “Design Of A Fiber To The Home FttH Access Network In Somalia Using Gpon Technology”, Which I Submitted As A Master Thesis, Is Written Without any assistance in violation of scientific ethics and traditions in all the processes from the Project phase to the conclusion of the thesis and that the works I have benefited are from those shown in the Bibliography.
(.../.../20...)

Abdikani Said MUSE

FOREWORD

Firstly, I would like to share my appreciation to my thesis advisor Assist. Prof. Dr. EYLEM GÜLCE ÇOKER for continuous support and motivation during the preparation of this thesis, secondly, I would like to thank to all Electrical and Electronics Department for their academic help and guidance through my master's degree and lastly but not least I am extremely thankful to my lovely wife, for her support and inspiration to finish this thesis.

June 2021

ABDIKANI SAID

TABLE OF CONTENT

	<u>Page</u>
FOREWORD	iii
TABLE OF CONTENT	iv
ABBREVIATIONS	vi
LIST OF FIGURES	viii
LIST OF TABLES	ix
ABSTRACT	x
ÖZET	xi
1. INTRODUCTION	1
1.1 Problem Statement	2
1.2 Project Background and Motivation.....	3
2. FUNDAMENTAL CONCEPT OF FTT-x- SYSTEM	5
2.1 Demands for Improved Bandwidth Requirement	5
2.2 Fiber- to -the x (FTT-x) networks	8
2.3 Design of an FTT-H networks	9
2.3.1 Point _to_ point configuration	10
2.3.2 Point_to_multipoint configuration	10
2.4 Advantages of FTTH.....	12
3. PASSIVE OPTICAL NETWORK (PON)	13
3.1 PON Topologies	17
3.1.1 Tree Topology	17
3.1.2 Ring Topology	17
3.1.3 Bus topology	18
3.2 GIGABIT PASSIVE OPTICAL NETWORKS (GPON).....	19
3.2.1 Component List of GPON -FTTH Access Network.....	19
3.3 Advantages and Disadvantages of GPON.....	21
3.4 Architecture -of G-PON- FTTH Networks	22
3.4.1 FTTH Core- Networks	22
3.4.2 Central -Office (CO)	22
3.4.3 Feeder -Network	23
3.4.4 Distribution- Network's areas	23
3.4.5 User Area	23
3.5 GPON Transmission and Basic Concepts	24
3.5.1 Security	25
3.5.2 Protection in GPON	26
3.5.3 Encryption System	26
3.6 Performance Parameters in GPON Network.....	26
3.6.1 Error- Rates	26
3.6.2 Q Factor.....	27
4. DESIGN OF THE GPON A FTTH ACCESS NETWORK	28
4.1 Optical- fiberoptic parameters.....	29
4.1.1 Wavelengths.....	29

4.1.2 Frequency	30
4.1.3 Dispersion	31
4.1.3.1 Chromatic dispersion	31
4.1.3.2 Modal dispersion	31
4.1.4 Bandwidth	31
4.2 Small Form Pluggable	32
4.3 Fusion Splicing	32
4.4 Connectors	32
4.5 Home Gateway	33
4.6 Calculation and Design Validation	33
4.7 Cost Calculations Of The Project	38
4.8 Location and Selection	38
4.9 Design, Simulations, Results and Distribution Network	39
5. CONCLUSION	49
REFERENCES	50
RESUME	Error! Bookmark not defined.

ABBREVIATIONS

FTTH	: Fiber to The Home
PON	: Passive Optical Network
TDM PON	: Time Division Multiplexing
WDM PON	: Wideband Division Multiplexing
ITU-T	: International Telecommunication Unit
GPON	: Gigabit Passive Optical Network
BPON	: Broadband Passive Optical Network
GFP	: Expectation Maximization
EPO	: Ethernet Passive Optical Networks
Mbps	: Megabit Per Second
P2MP	: Point to MultiPoint
OSP	: Outside plant
OLT	: Optical Line Terminal
QoS	: Quality Of Services
F/O	: Fiber Optics
FTTB	: Fiber to The Business
FTTC	: Fiber to The Curb
FTTN	: Fiber to The Business
FTTO	: Fiber to The Office
SNI	: System Network Interface
CO	: Central Office
P2P	: Point To point
TDMA	: Time Division Multiplexing Access
APON	: Passive Optical Network
ONT	: Optical Network Terminal
ONU	: Optical Network Unit
IEE	: Institute of Electrical and Electronics Engineers
OS	: Optical Splitter
GFP	: Generic Framing Procedure
EMI	: Electromagnetic interference
EMC	: Electromagnetic Compatibility
PSTN	: Public switched telephone network
ODF	: Optical Distribution Frame
ISP	: Internet service provider
FDT	: Fiber Distribution Terminal
FAT	: Fiber Access Terminal
TB	: Terminal Box
ATB	: Access Terminal Box
AES	: Advanced Encryption Standard
BER	: Bit Error Rate
SNR	: Signal to Noise Ratio
Q -Factor	: Quality Factor

OTDR	: Optical time-domain reflectometer
LED	: Light Emitting Diode
MHz	: Mega Hertz
SFP	: Small Form pluggable
FS	: Fusion Splicing
LC	: Lucent Connector
SC	: Subscriber Connector
HGW	: Home Gateway
PTX	: Transmitted Power
PRX	: Received Power
LB	: Link Budget
MTU	: Multiple Tenant Unit
ODN	: Optical Distribution Network
OSNR	: Optical Signal-to-Noise Ratio
PRBS	: Pseudo Random Bit Sequence
SMF	: Single Mode Fiber
US	: Upstream
NRZ	: Non-Return-to-Zero
MZM	: Mach-Zehnder Modulator
MUX	: Multiplexer
LANs	: Local Area Networks
Laser	: Light Amplification by Stimulated Emission of Radiations
IPTV	: Internet Protocol TV
FTT	: Fibre_to_the-x
FTTCab	: Fibre_to_the_Cabinet
DSL	: Digital Subscriber Line
DS	: Down Stream
BW	: Bandwidth
GHz	: Giga Hertz
Km	: Kilometer
M	: Meter
Mbps	: Megabit per second
Nm	: Nanometer
Ps	: Picosecond
µm	: Micrometer

LIST OF FIGURES

	<u>Page</u>
Figure 2.1: Cellular Phone data traffic increase. Fount Cisco VNI Mobile Prediction-2013	7
Figure 2.2: Some FTTx scenarios	9
Figure 2.3: Point to Point (P2P) FTTH case	10
Figure 2.4: Point to Multipoint (P2MP) case	11
Figure 2.5: The Cost-Distance Relation of P2MP and P2P	11
Figure 3.1: Tree with single splitting point	17
Figure 3.2: Ring Topology	18
Figure 3.3: Bus topology	18
Figure 3.4: Typical GPON architecture	19
Figure 3.5: Architecture of GPON FTTH Network	22
Figure 3.6: traffic in the downstream-direction	24
Figure 3.7: BER versus the Q Parament	27
Figure 4.1: GPON FTTH access network design steps	29
Figure 4.2: Typical optical transmission wave	30
Figure 4.3: Frequency Measurement	31
Figure 4.4: connector block diagram	33
Figure 4.5: Afgoye project area map	39
Figure 4.6: design and distribution network of the project	41
Figure 4.7: Downstream GPON simulation in Opti-system for Single User	42
Figure 4.8: Q Factor	43
Figure 4.9: Min. BER	44
Figure 4.10: Eye Diagramand it	45
Figure 4.11: A blocks Splitter Block Diagram	46
Figure 4.12: B2 blocks Splitter Block Diagram	47
Figure 4.13: C blocks Splitter Block Diagram	48

LIST OF TABLES

	<u>Page</u>
Table 3.1: TDM Passive Optical Network (PON) standards	14
Table 3.2: splitters losses	21
Table 3.3: Transmission Bit Rates of GPON	23
Table 3.4: GPON Specifications	25
Table 4.1: Calculation of the cost of the project	38
Table 4.2: project information and number of users	39
Table 4.3: Result table.....	42

DESIGN OF A FIBER TO THE HOME FTTH ACCESS NETWORK IN SOMALIA USING GPON TECHNOLOGY

ABSTRACT

This thesis is about a step-by-step design of a secure GPON Fiber optic to the home FTTH access networks, serving 837 users in Afgoye city in Somalia. The fundamental list component of the project is explained well and the involvement of every element of the FTTH is addressed, in this project FTTH fiber system starts from telecom main hub and ended inside the apartments. Fiber -to -the home (FTT-H) is communication technology which delivers a communication signals from the telecom main hub all the way to the apartments or commercial places, thus taking over existing copper wires structure for instance telephone wires and coaxial cable. Fiber to the home is a fast -developing system that supplies fast internet to the customers and businesses. In this project single mode fibers have been used, connection devices have been selected properly and all datasheets, calculations, maps are attached to the project.

Keywords:*GPON, Fiber to The Home, BER and PON Optical Splitters*

GPON TEKNOLOJİSİ KULLANILARAK SOMALYA'DA EV FTTH ERİŞİM AĞINA BİR FİBER TASARIMI

ÖZET

Bu proje Afgoye, Somalide bölgesindeki yeni yapılan konutların Gigabit Passive Optical Network (GPON) altyapı tasarımı hakkındadır. Bu GPON projesinde Fiber to the Home (FTTH) sistem seçilmiştir. Bu projenin amacı, fiberoptik sistem kullanılarak daha hızlı ve daha güvenilir veri iletimi sağlamaktır. FTTH projesinde, fiberoptik sistem Telekom santralinden başlayıp konutların içinde sonlanmaktadır. FTTH tek bir fiber optik ağı üzerinden çoklu uygulama ve servis hizmetlerini sağlayan iletişim teknolojisidir. Bu servis hizmetleri telefon, internet ve televizyon gibi temel hizmetlerin yanı sıra daha gelişmiş , evdeki cihazların uzaktan kontrolü gibi uygulamaları içerir. Bu projede tek modlu fiber kullanılacaktır. Alıcı/verici, bölücüler ve diğer bağlantı cihazları uygun şekilde seçilmiş ve bütün hesaplamalar, haritalar, çizimler ve cihaz katalogları projeye eklenmiştir.

Anahtar Kelimeler: *GPON, Eve Kadar Fiber, BER ve PON Optik Bölücüler*

1. INTRODUCTION

The underlying operator for the modern access technologies that allow true broadband is the growing demand for high-speed internet. It pushes telecommunications companies to seriously explore large-scale deployments of optical-fiber-based access networks. They should upgrade their access networks, which are now a bandwidth bottleneck. As a result, most telecommunications operators are phasing out their legacy copper networks in favor of switching to or transferring to optical fiber networks. The fiber optical fiber develops nearer and nearer to the customer in order to have faster links. For a long-term goal, FTTH (Fiber to the Home) seems to be the best option. It would be possible to expand capacity in the future if users are entirely covered by optical fibers. FTTH is the future proof approach for providing broadband content for instance video on request, online gaming, HD television, and VoIP. In our case, a PON-based FTTH access network is a point-to-multipoint, fiber-to-the-premises network architecture in which unpowered optical splitters are used to enable a single optical fiber to deliver multiple premises, typically 32 to 128 (Jagjit Singh Malhotra, 2014) . FTTH (Fiber -to -the Home networks) success the small attenuation from (0.2 to 0.6 dB per km) and high-level bandwidth larger than (30000GHz) of single -mode --optical fibers (Dirk Breuer et al., 2011)to give several instances extra bandwidth than current obtainable with present wideband tools. Additionally, these networks may deliver all networking capabilities, such as voice, data, and video, from a single network platform. For FTTH implementations, several Time Division Multiplexing TDM-PON technologies are standardized. The summary of these standards with their important parameters can be seen at table 3.1 , [TDM-PON (time division multiplexing passive optical network) has the big drawback of preventing separate operators or networks from physically using the same cable. As a result, a multi-fiber implementation is critical for sharing the access network physically. The next generation of access networks is WDM-PON (Wavelength Division Multiplexing Passive Optical Networks. The two types of WDM_PON analyzed

by the International Telecommunication Union (ITU_T) research group -15 (SG-15) (Dirk Breuer et al., 2011). The first is period and wavelength section multiplexing PON (TWDM_PON), that communicates up to 16 wavelengths on the same fiber to enable more than one operator to use the same fiber, for example. Different wavelengths are available to operators . The second will be an organized waveguide grinding (AWG)_built WDMPON that will offer each one user with a reserved wavelength, equivalent to point to point (P2P), with a downlink and uplink transmission capability of 1.25 Gbps (Golberg.). The FTTH architecture of the gigabit passive optical network (GPON) provides joined information and voice services of up to 2.5 Gbps. A gigabit passive optical network can carry a variety of services in their native format, including time division multiplexing (TDM) and data. To make the transition from BPON to GPON easier, different types of BPON functions are reused for GPON. The GPON instructions are ITU-T Recommendations G-984.1 to G-984.5. The Gigabit Passive Optical Network (GPON) uses the Generic Framing Procedure (GFP) protocol to provide complete support for both voice and data-oriented facilities. The main advantage of GPON over other modes is that it offers interfaces to all major facilities, and packets from different protocols can be transmitted in their native formats in GFP enabled networks. (Rajneesh Kalera and R.S. Kalerb, 2011). The GPON is now one of the most widely used PON inventions, with the other standards PON (EPON). The ITU-T recommendation G.984 sequence defines GPON. As previously said, the GPON interface will transfer data over optical fibers at an asymmetrical bit rate. Through using the GPON encapsulation process, G-PON can carry ATM-TDM, and Ethernet traffic (GEM). This study examines the architecture and implementation of a FTTH access network focused on G-PON for newly arrived Somalis. The proposed architecture supports a capacity of 837 users, has an average downstream bandwidth of 62.2-Mbps and an upstream bandwidth of 31.1 Mbps, and adheres to the power budget and rise time budget standards.

1.1 Problem Statement

With the enlargement and development of communication technologies, optical fiber is the one of the greatest and essential communication technologies in the

access network. Passive -optical -network (PON) is a network that causes optical-fiber signal to the end customers by point_to_multipoint (P2MP) fiber-to the users. Another aspects of fiber to the home (FTTH) access systems have stayed examined in literature address subject associated to outside plant OSP (Satyanarayana Katlay and Abhinov Balagoni, 2013) that considers the power effectiveness of those networks, some aspects related to the operation cost related with fiber to the home (FTT-H) networks are discussed in (Rajneesh Kalera and R.S. Kalerb, 2011) , some of them discussed accessibility modeling of these systems, and discuss aspects and tests related to following generation passive optical networks (PONs) . though, the outcomes of the ones as it is mentioned above research could not discuss getting faster and more reliable data transmission using gigabit passive optical network. In addition, despite their relevance and support from well-known OLT brands, single mode fibers have not been considered in the study of any of these studies in terms of bandwidth and speed for efficient transmission. The need for this project stems from a scarcity of access network field experts. Furthermore, this study offers practical experience with the architecture, validation, and deployment of GPON FTTH access networks.

The aim of this project is to provide a detailed study and theory of gigabit passive optical networks (GPON), as well as a step-by-step concept and field realization of a gigabit passive optical system (GPON FTTH) access network.

1.2 Project Background and Motivation

This thesis aims are to give basic information about:

Gigabit Passive -Optical -Network (GPON-) access technologies, BER- Bit Error rate for one single user, is to provide faster and more reliable data transmission using the fiber optic system.

Passive optical network (PON) standards and technology and comparison with GPON Gigabit -Passive -Optical -Network (GPO-N) is one of the PON standards. It varies from other passive optical network (PON) - standards in which it reaches better bandwidth and advanced proficiency applying greater and variable length packages. It is also commonly considered to be the greatest

candidate for widespread deployments. It gives lower maintenance costs because of the presence of passive components in the physical plant and decreases deployment costs through sharing of fiber medium. These technologies do not exist in Somalia and the reason of chosen this research is to be the first person who have done this project in theoretical and also practical way.

2. FUNDAMENTAL CONCEPT OF FTT-x- SYSTEM

The use of passive optical network equipment for giving broadband connectivity in the gain access to system to homes and several occupancy entities, and the minor enterprises mostly is known as Fiber to the X. for this purpose is given the description of FTT-X .

FTTH is the carrier of a communication signals over an optical fiber from telecom hub to all the way to the business or home, instead of a regular copper framework for instance telephone wires. Fiberoptic to -the home (FTTH) is almost rapidly developing new, and the process of offering have very high bandwidths to subscribers providing more internet and voice services, robust video.

In comparison to previous technology or conventional internet communication systems such as DSL, Fiber to The Home (FTTH) is the extremely encouraging technology which can deliver a very high-level bandwidth with more flexibility and therefore an extremely high Quality of Service in short (QoS). These technologies are based on optics, which employs fiber optics (F/O) to link the internet connection to the customer, which is the end-user. Fiber to the home (FTTH) is an access infrastructure of many styles that will be discussed. Furthermore, FTTH is a highly adaptable technology that can be installed and used in any region., but also there are many differences that are found in the country policy and the geographic area of the end-user is very independent.

2.1 Demands for Improved Bandwidth Requirement

Nowadays, business triple play administration bundles offer common place transmission capacities somewhere in the range of 20 and 100 Mbps to private clients. As indicated by Nielsen's Law, which predicts that a top-of-the-line client's Web association increments by 50% consistently, one could conceive that a supporter appreciating a 58_Mbps administration in 2013 should need 130-Mbps constantly 2016. Moreover, the European Committee have set an

objective which by -2020 portions of all families in Europe ought to have broadband memberships at velocities of in any event 100 Mbps. Albeit current advancements, like GPON- handles meetings to the small for short term requirements of private customers, over the more extended term they will battle to answer the necessities of profoundly requesting administrations such as HD-TV and 3D_TV, various picture and point video administrations, development in a unicast video (versus- multicast) distributed calculating, multiplayer HD video -gaming and additional. It is foreseen that the most elevated transmission capacity (bandwidths -needs) requests will take place from small business clients and versatile transceivers that are now beginning to exploit FTTH organizations to convey their information content. The greater transfer speed accessible through optical gain access to systems addresses an appealing, lower cost choice contrasted with a rented line or devoted highlight viewpoints Ethernet association. By 2020 it is assessed which there will be 50 billion associated gadgets utilizing the fixed and portable broadband organization. This will make the organized society, wherein everything profiting by an association will have one. From 2012 to 2017 the aggregate sum of information traded between portable clients is relied upon to increment by 66 percent every year, as indicated by Cisco's Visual Networking List. The colossal development in versatile information will put gigantic tension on administrators.

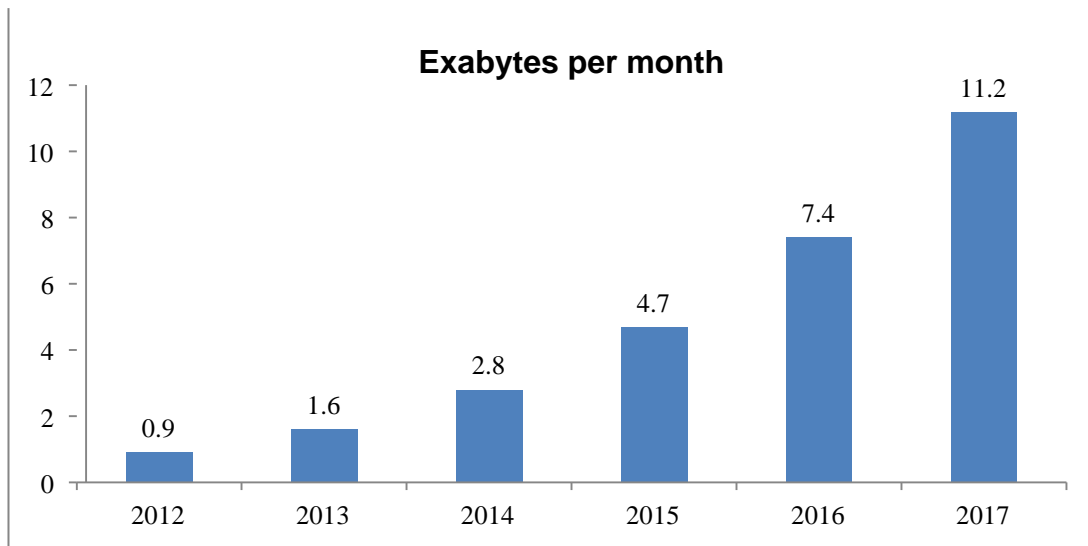

Figure 2.1: Cellular Phone data traffic increase. Fount Cisco VNI Mobile Prediction-2013

Business administrations and portable transceivers are relied upon to require supported, symmetric information paces of 1 Gbps and past, while private clients might be less requesting on the grounds that require the pinnacle transfer speeds for more limited lengths. Symmetric high-data transfer capacity pipes are not generally accessible over current-age FTTH organizations nonetheless, because of absence of data transfer capacity assets and the asymmetric model of present PON skills. Cutting edge PON will power address this topic while likewise giving the higher transfer speed and nature of administration levels that these administrations require. Assembly of voice and information administration on a solitary optical organization has demonstrated to be the privilege decision for provincial and center organizations comparative efficiencies could be accomplished in the entrance network. Bigger split proportions, expanded reach, frequency accessibility and fiber reuse can empower administrators to serve up more clients with less speculation.

Cutting edge PON-s will empower the smooth advancement from existing optical access organizations, which are basically private, to combined access networks containing private, business administrations and portable transceiver.

2.2 Fiber- to -the x (FTT-x) networks

In the field of telecommunications, fiber to the home (FTTH) networks are part of the FTTx transmission system band. Broadband networks can carry extremely large amounts of data and info at extremely high-level bit rates up to a point similar to or exactly to the end user FTTx refers to a group of technologies that use optical fiber as a communication medium to transport digital signals. Different degrees of coverage occur because of a bigger or smaller cost decrease of these devices, varying on the grade of optical fiber that is near to an end consumer. Both members of the FTTx family accept logical network configurations such as tree, loop, bus, and star, as well as the ability to use active components depending on the address or location of users or end premises.

These networks can be divided into the following categories based on the degree of FTTx penetration .

- Fiberoptic _to _the_ business (FTTB) implies to the installation or configuration of optical fiber from a central office transfer into a company.
- Fiber to the curb (FTTC) refers to operating optical fiber cables from a central office tool to a networking switch that is more than 1000 feet away (about 300 meters) from an organization or home.
- Copper cables, twisted pair, coaxial cable (e.g., for DSL), or some of other transmission medium can be used to connect the curbside tools or equipment to users in a building.
- FTTH stands for fiber to the home, which refers to the installation of optical fiber from a CO (central office) switch into consumers' homes. The only distinction between FTTH and FTTB is that companies often need more bandwidth for a longer period of time than do home users. So that a network service supplier can generate or receive more money from FTTB systems, as well as regain construction expenses faster than FTTH systems.

- Fiber _to _the city, or FTTN, is a passive optical network design in which optical fiber cables penetrate --3000 feet (approximately 1 km) of businesses and homes.

FTTO, or fiberoptic to the office, is comparable to FTTB in that an optical route is provided all the way to a commercial client's premises.

Alcatel uses the term FTTU (fiber-to-the-user) to illustrate their goods for FTTB and FTTH applications.

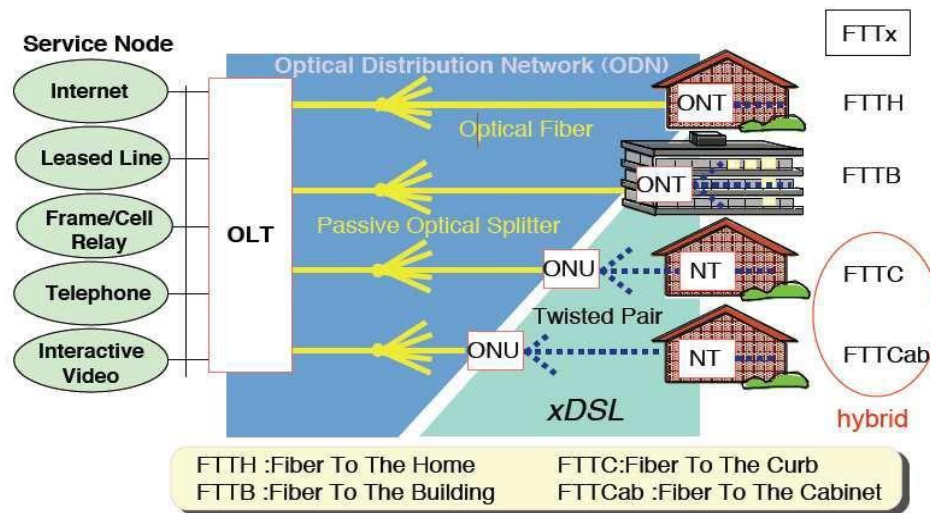

Figure 2.2: Some FTTx scenarios .

Figure 2.2 shows different architectures that employ optical fiber in the local access part. FTTH has optical fiber optics all the means from the OLT at the local exchange and where we have SNI (Service Node Interface) to the user premises where we have ONT. In FTTB/C we don't have fiber going directly to the user, but it is terminated before that in the building or some other mid-way where there is an ONU. The purpose of ONU is to have optical electrical interface for conversion of signals in the two domains. In FTTCab the ONU is in the street cabinet where this optical to the electric and electrical to -optical transformation is carried out.

2.3 Design of an FTT-H networks

The integration of fiber optics into the global network is aided by FTTH technologies, in both cases by the backbone network provider as the final step.

It also contains the fiber from the CO (central-office) to each customer (subscriber) who wants or requires services, in addition to the last move.

The physical configurations mentioned below can be used to link the end user to the delivery point (node) that will provide the services.

2.3.1 Point _to_ point configuration

When it comes to optical fiber, point to point configuration refers to the link or connection between the central node and the end user. Companies who have connections to fiber optic in their outside plant and require joining distant areas for some networking capacity, which can range from a voice or telephone service to a high-speed data link, run point-to-point transmission. When it comes to the network's active portion in addition to WDM, it is important that the methods used for data transfer in point-to-point connections are PDH or SDH. These links have a lot of power and capability, and they are very useful in industry. There are subscribers at a distance of D km from the central office in Figure 2.3.

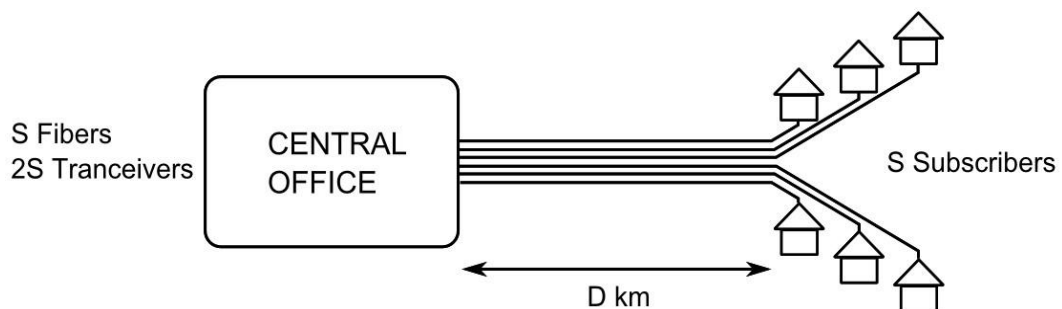

Figure 2.3: Point to Point (P2P) FTTH case

2.3.2 Point _to_ multipoint configuration

Where it comes to fiber optics, point to multipoint configuration is where FTTH networks are designed. In most cases, this arrangement is described as a passive optical network (PON).

In the last stage or final step, structural design built on passive optical systems is defined as an international framework lacking active electronic components. Since it is the most crucial aspect of this study.

The cost of service and installation for point to multipoint (P2MP) is lower than for point to point (P2P) since the common parts cost is shared among all

customers or users served by the same fiber. Figure 2.4 reveals that at a distance of D km, there is only one fiber optic cable serving customers .

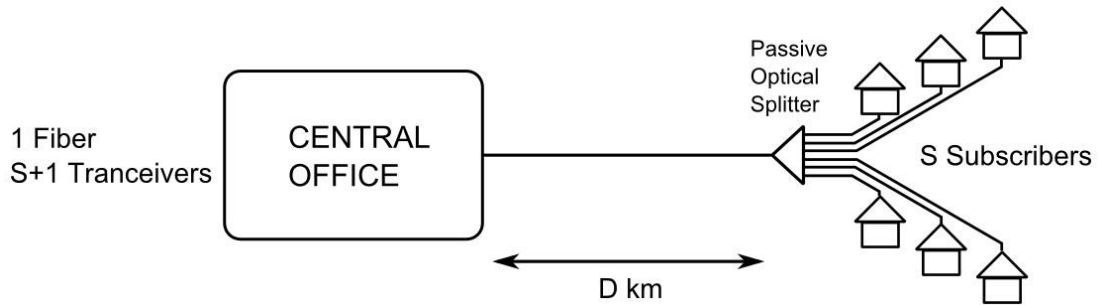

Figure 2.4: Point to Multipoint (P2MP) case

In arranging and planning the organization the main issue is the cost. talked about the three situations with their focal points and drawbacks. In estimation of the cost, the space among the Central Office and also the supporter is the deciding part. In Figure 2.5 the distinction regarding the cost between the P2P and the P2MP networks is appeared. As indicated by the paper distributed , the underlying cost of the P2MP network is higher than that of the P2P because of the additional equipment utilized in the field, and this consistently diminishes as the separation from the specialist organization increments up to a specific distance, where the expenses of both will be equivalent (the breakeven point). Past that distance the P2MP will consistently be more affordable than the P2P, and the distinction in the expense between the two frameworks increments straightly as the distance gets bigger.

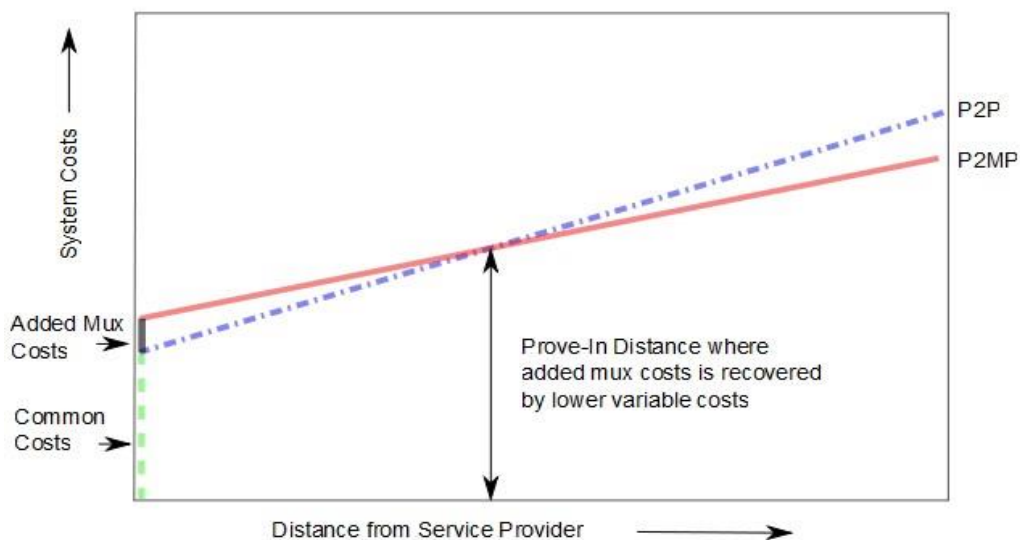

Figure 2.5: The Cost-Distance Relation of P2MP and P2P

2.4 Advantages of FTTH

There are distinct types of Advantages of fiber -to -the home.

- From the central office to the end customer, there are no active modules. Because it is a static network.
- This eliminates the need for a DC power network while further lowering network maintenance costs and requirements.
- It's a single fiber to the end customer that provides operating income offerings like audio, high-speed data, analog or digital CATV, DBS, and video on demand via industry-standard user interfaces.
- FTTH has two essential advantages: local battery protection and low power consumption.
- FTTH is a dependable, scalable, and stable technology. One of the future-proof architectures is the FTTH network.
- Since it is a service delivered over optical fiber, FTTH bandwidth is comparatively large.

3. PASSIVE OPTICAL NETWORK (PON)

The Passive- optical -network (PON) is a system that by its nature gives a multiplicity of broadband essential customer services to subscribers all through optical fiber. And its distribution networks do not use electronic signal regeneration. Passive optical elements are positioned in the access network rather than active components to guide the distinct light wavelengths (1490 nm. For downstream 1310 nm and 1550 nm for upstream) For RF TV through the fiber optic cable from central office to user and vice versa. Passive optical components do not need power to operate or any other signal routing/regenerating processes. These parameters decrease the additional operational costs for the operator. Presence of passive components construct the distribution network means that every future upgrade will be is cheaper and less painful because only the two end-point devices need to be upgraded or changed.

Fiber optic access networks, or PONs, Fiber optic networks are a form of fiber optical network. In most cases, downstream signals are broadcast to all users that share several fibers. Eavesdropping can be prevented with encryption. Multiple access protocols, such as time division multiplexing, are used to merge upstream signals (TDMA). There are different types of standards or in other words technology in the present PON architecture, the first one, APON (Asynchronous _Transfer _Mode _ATM Passive Optical System) which have downlink maximum rate of 155-Mbps and later amplified to 622-Mbps. The second B-PON (Broadband -Passive Optical- Network) B-PON networks also are supports ATM cell communication nevertheless they need the change regarding to APON since they sustenance additional wideband standards in the primary type BPON systems were described under a limited and fast rate of 155 Mbps transmission for upstream and downstream although later has been changed asymmetric channels. Downlink: 622 Mbps and Uplink: 155Mbps. The second one Ethernet Passive Optical Networks (EPON), is standardized and established by Association of Electrical and Electronics Engineering (IEEE),

Since it is Ethernet compatible, it can run at GBPS rates directly. This flow does not have a single user so it must be shared by multiple users (ONT) due to the system's limitations. The International Telecommunication Union (ITU) has standardized and developed Gigabit Passive Optical Networks (GPON) (ITU). GPON will be discussed and expanded upon in this thesis. For FTTH implementations, numerous Time -Division-Multiplexing- TDMPON tools have been standardized. Table 3.1 summarizes these specifications and their key parameters.

Table 3.1: TDM Passive Optical Network (PON) standards

Parameter	EPON	BPON	GPON	XGPON	10G-EPON
Standard	IEEE 802.3ah	ITU-T G.983	ITU-T G.984	ITU-T G.987	IEEE 802.3av
Downstream data Rate	1.25 Gbps	622 Mbps	2.5-Gbps	10-Gbps	10-Gbps
Upstream data Rate	1.25-Gbps	155-Mbps	1.25-Gbps	2.5-Gbps	10Gbps/Symmetric 1 Gbps/Asymmetric

Alternatively, beyond support for various transmission rates allows all data (uplink and downlink) to be transmitted on a single single-mode fiber (as described by the ITU-T G.652 standard), with a maximum distance of 20 km between the optical splitter (OS) and the optical line terminal (ONT), as well as among ONTs of the equal level. The job wavelengths which set the standard BPON are different based on whether you make use of one or two fibers for every ONT, but all situations have a devoted wavelength for video transmitted from the OLT to the ONT, which is distinct from those used for voice and data transmission. The below are the wavelengths.

For single one fiber each O-N-T, sharing uplink and downlink:

Downlink/stream channel $\lambda=1480$ to 1500 nm

Uplink/stream channel: $\lambda=1260$ to 1360 nm

For Video: $\lambda=1550$ to 1560 nm

Broadband passive optical network (B-PON) involves a highest ratio of 32 optical splitters for each O-L-T, and for every splitter adopts capable of 64 outputs to ONT clients. This gives a sum of

$$Users_{MAX} = 32 \frac{Splitters}{OLT} * 64 \frac{Users}{Splitters} = 2048 \frac{Users}{OLT} \quad (3.1)$$

For Ethernet passive optical network (EPON) involves a highest ratio of 16 splitters for each OLT, and each divider involves a maximum of 64 outputs to ONT users. This gives as a total of

$$Users_{MAX} = 16 \frac{Splitters}{OLT} * 64 \frac{Users}{Splitters} = 1024 \frac{Users}{OLT} \quad (3.2)$$

This means that the model involves a smaller amount of the number of O-N-T users linked and in service to the similar OLT, according to B-PON standard. Almost, the difference between both will be,

$$\frac{Users_{B-PONMAX}}{Users_{EPONMAX}} = \frac{2.048 \frac{Users}{OLT}}{1.024 \frac{Users}{OLT}} \quad 2 \text{ times more than EPO} \quad (3.3)$$

On the other hand, although the EPON standard relates decrease the quantity of ONTs associated to the equivalent OLT, the velocity ratio also improved in the same percentage regarding B-PON in its fundamental structure, as following.

$$\frac{Ratio_{EPON}}{Ratio_{B-PON}} = \frac{1244Mbps}{622Mbps} \quad 2 \text{ times more speed than B-PON} \quad (3.4)$$

Lastly, it's important to note that, considering the fact that EPON is a faster norm than B-PON, it doesn't go much further because the maximum gap among the OLT and ONTs maintains the proportionality seen below.

$$\frac{Reach_{EPON}}{Reach_{B-PON}} = \frac{20Km}{10Km} \quad (3.5)$$

Gigabit passive optical network (G-PON) allows distinct broadcast levels the scale of among 622 Mbps (as a predecessor B-PON) to 2.488 Gbps in the downlink network.

The philosophy of having very high bandwidth allows for the transfer of almost all multimedia data and facilitates any operator operation. Furthermore, GPON global support multiservice due to their complete assistance (either via TDM ATM or over Ethernet and ATM). Each ONT has a single fiber that is shared for transmission.

Downlink channel- $\lambda=1480$ to 1500 nm

Uplink channel- $\lambda=1260$ to 1360 nm

Video: $\lambda=1550$ nm

Finally, each OLT can have up to 128 splitting ratios, and each splitter can have up to 64 outputs to ONT consumers. As a result, we have a total of.

$$Users_{MAX} = 128 \frac{Splitters}{OLT} * 64 \frac{Users}{Splitters} = 8.192 \frac{Users}{OLT} \quad (3.6)$$

The GPON norm provides for a substantial increase in the number of ONTs attached to the same header OLT.

$$\frac{Users_{GPONMAX}}{Users_{EPONMAX}} = \frac{8.192 \frac{Users}{OLT}}{1.024 \frac{Users}{OLT}} \quad 8 \text{ times more users than EPON} \quad (3.7)$$

As can be shown, there is a significant gap between them, implying that GPON technology allows for lower deployment costs by requiring less deployed OLTs to cover a given region.

In terms of transmission rate, GPON increases data transfer speed, with the following ratio between the standards.

$$\frac{Ratio_{GPON}}{Ratio_{BPON}} = \frac{2,44Mbps}{622Mbps} \quad 4 \text{ times faster than BPON} \quad (3.8)$$

The distances amongst the OLT title and various ONTs are also increasing at a rapid pace, as measured by the following ratio:

$$\frac{Reach_{GPON}}{Reach_{BPON}} = \frac{60Km}{20Km} \quad 3 \text{ times more reach than BPON} \quad (3.9)$$

In conclusion, based on the empirical data comparison between some standards and others, the GPON standard can be described as a standard that can transmit data up to 4 times faster and provides improved stability because it has a stable communication procedure level, adding fields in ATM or Ethernet. Much on this subject will be discussed in the following pages of this thesis.

3.1 PON Topologies

A passive optical network (PON) is a type of fiber-optic network that uses optical splitters (OS) to transmit data from a single transmission point to multiple subscriber endpoints in a point-to-multipoint topology. There are three different kinds of PON topology.

3.1.1 Tree Topology

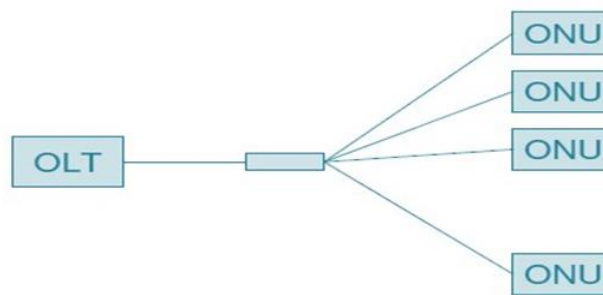

Figure 3.1: Tree with single splitting point

In fiber optic connection networks, the tree topology is the most general. The tree with a single splitting point (see Figure 3.1) is particularly common for PON. It connects an optical line terminal (OLT) to a remote node (RN), which is a medium splitting point, with a single fiber. Any ONU connected to the network receives an isolated fiber from this splitting point. The most significant benefit of this topology is that the separation is done only once. As a result, adopting a single power budget for all ONUs is easy, implying that they all absorb or relay roughly the same optical signal power and quality.

3.1.2 Ring Topology

There are two primary methods to meet the optical line terminal (OLT) from each ONU in a ring topology. (See Figure 3.2 for more information.) In the

event of a fiber cut, the link can always be established and maintained. According to the power budget, ring topology has the equal disadvantage at the same time as the bus. The optical signal is degraded and attenuated as it goes through multiple couplers. As a result, the maximum number of ONUs or OLT which can be linked to the ring PON is reduced as well (M. Chardy et al., 2012).

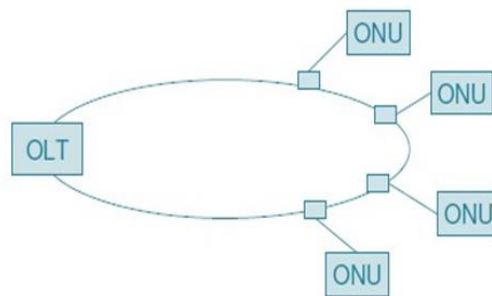

Figure 3.2: Ring Topology

3.1.3 Bus topology

It can also be called a specific case of tree topology since each ONU or OLT is attached to a tap coupler that can abstract a portion of the power sent by the optical line terminal (OLT).

The below are the two primary benefits:

1. Optical fiber use is kept to a bare minimum.
2. adaptable deployments, as new ONUs may be added to the network by inserting more taps.

The issue, on the other hand, is that the OLT or ONU signals, which must pass through multiple tap couplers, are weak and degraded. As a result, the number of ONUs that can bind to the PON bus is limited. Furthermore, applying the cost-effective security scheme to the bus topology is difficult .

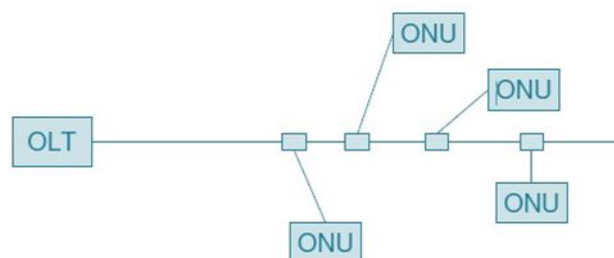

Figure 3.3: Bus topology

3.2 GIGABIT PASSIVE OPTICAL NETWORKS (GPON)

GPON is fiber to the home architecture which has been used before. The GPON architecture is simple, cheap, and easy to operate fiber-based networks possible. The Generic Framing Procedure protocol (GFP) is used by the GPON to provide protection for both voice and data set facilities. A significant benefit of GPON over other systems is that it provides interfaces to all of the major facilities, and packages be appropriate to various procedures could be distributed in their natural setups in GFP supported networks . The Figure below shows typical architecture of GPON.

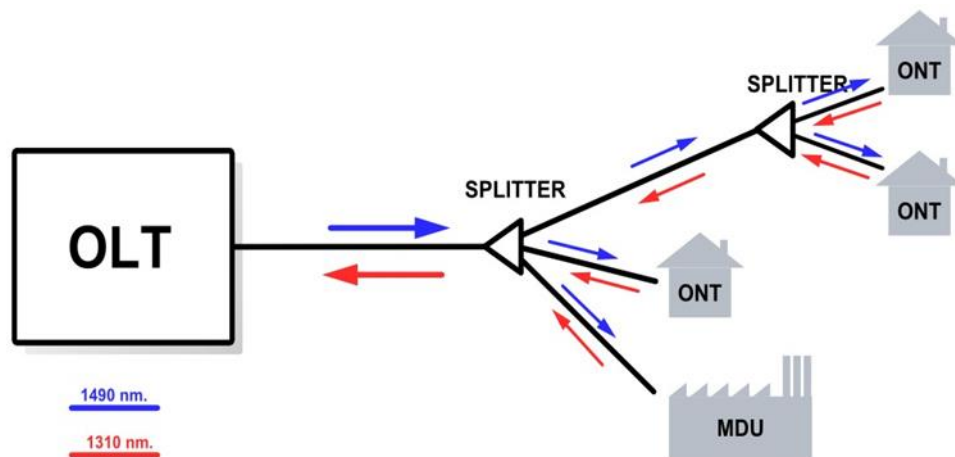

Figure 3.4: Typical GPON architecture

3.2.1 Component List of GPON -FTTH Access Network

On the authority of ITU-T G.984 recommendation, the fundamentals of GPON is stated the Figure 3.4 the summary of These components can be as following. Optical Line Terminal (O-L-T), Optical Networks Termination (O-N-T) and Optical Splitters (OS).

Optical Line Terminal OLT

The OLT (Optical -Line -Terminal) is the system's main component, and it's usually found in the central office. It's the engine that powers the FTTH system [29]. Traffic scheduling, bandwidth distribution, and buffer management are the three most important tasks performed by OLT (Rajneesh Kalera and R.S. Kalerb, 2011). Optical line terminals usually use unnecessary DC control (negative 48VDC) and have no less than one Route card for arriving internet, one Method Card for onboard setup, and one to distinct GPON cards. Every

GPON card has several GPON ports. To support different services simultaneously for the same fiber and for every direction, distinct wavelengths for every service are used. For the downlink direction, Gigabit passive optical network uses wavelength 1490-nm for compound data and 1550 nm wavelength for RF video. In the uplink direction GPON uses 1310 nm for combined data. Passive -wavelength division -multiplexing (W-D-M) couplers make the wavelength consolidating and separating functions.

Optical -Network -Terminal ONT

Optical Network Terminals (ONTs) are located at client's buildings. Optical network terminals are linked to the optical line terminal (OLT) with the help of optical fiber and no active components are current in the connection. In the uplink direction the optical network terminal (ONT) has to transmit data that coming from the subscribers' devices like telephone, computer or television to the OLT and in the downlink direction could also deliver the data come from the O-L-T to the customer's devices. For variety kinds of telecommunication services and subscribers according to numbers there are different types of ONT configurations and designs. An ONT could be set up in small size and installed to the outside of the premises. For only one user or can be set up in complex and bigger size like Multiple Tenant Unit (MTU) and installed inside of a building for more than one user.

Optical Splitters

The key components of GPON are optical splitters, which are passive power dividers that enable communication among the optical line terminal (OLT) and the corresponding optical network terminal (ONT). On the other hand, splitters are bidirectional optical supply machines which have one input and also multiple outputs that are not just devoted to multiplex or demux signals but also carry together the power.

The following properties should be present in a passive- optical- splitter. Broad operation wavelength variety

- low point insertion loss and uniformity in any circumstances
- the proportions should minimum

- the reliability must be high.
- protection policy and support network survivability

$$Attenuation_{Splitter} = 10 \log \frac{1}{N} \tag{3.10}$$

Normally there is two common types of splitters.

- splitter based on planar technology we use this one split ratio greater 32.
- splitters based on fused bi-conical couplers for split ratio less than 32.

1. the table below shows that typical losses due to split ratio and output.

Table 3.2: splitters losses

Splitter Ratio	1 to 2	1 to 4	1 to 8	1 to 16	1 to 32
Ideal Loss (dB)	3	6	9	12	15
Excess Loss (dB-max)	1	1	2	3	4

3.3 Advantages and Disadvantages of GPON

The advantages of GPON technology is as follows:

- do not require electricity and backup power sources .
- no need for environmental control devices .
- the risk or danger from the power sources is less or no danger at all.
- no Electromagnetic Interference (EMI) or Electromagnetic Compatibility (EMC).
- future use that require high bandwidth is going to be easy and simple due to the simple upgradable components

According to these advantages GPON became the most famous architecture among others. For instance, the ability to carry the signals with long distances need less equipment like repeaters so if the equipment's are less we can say that the points of failure will be less which makes high the reliability and quality of

the network. Apart from these advantages GPON has some disadvantages, the optical splitters will have optical losses which can limit the GPON.

3.4 Architecture -of G-PON- FTTH Networks

A tree topology is used in gigabit passive optical networks to optimize coverage while minimizing network breaks and lowering optical capacity (Salah Al-Chalabi, 2012). As seen in Figure 3.5, a FTTH access network consists of the following areas, a core system area, a central office region, a feeder region, a delivery area, and a user area.

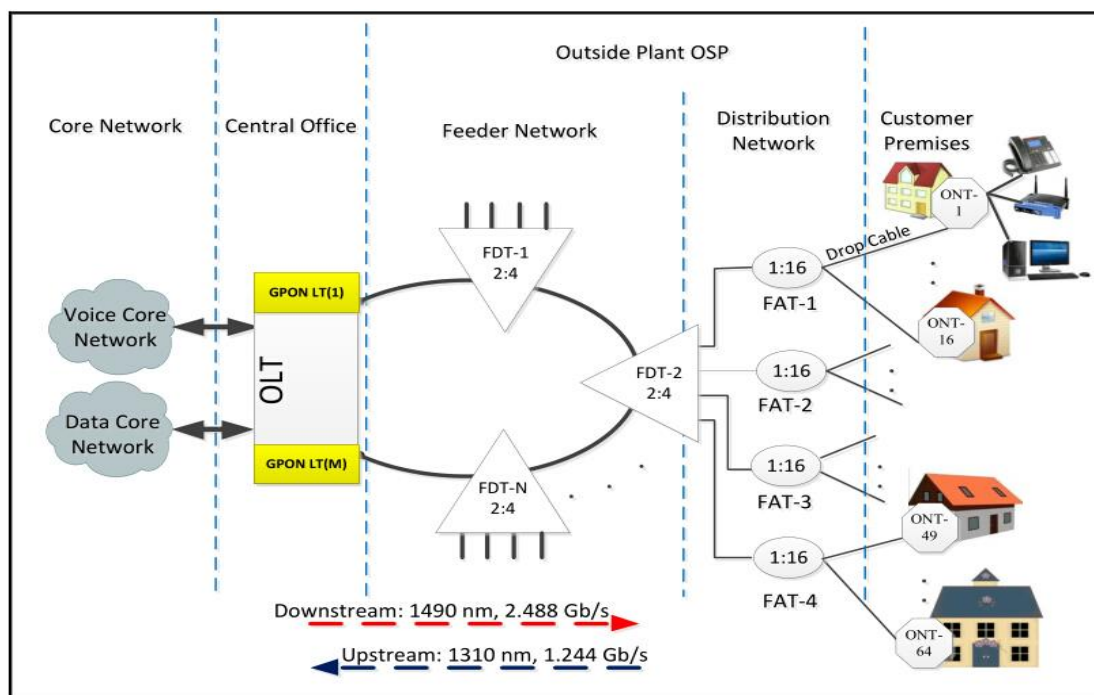

Figure 3.5: Architecture of GPON FTTH Network (Salah Al-Chalabi, 2012)

3.4.1 FTTH Core- Networks

The internet service provider's (ISP) equipment is located in the core network. PSTN (packet switching telephone network, or legacy circuit switched telephone network) and cable TV provider facilities.

3.4.2 Central -Office (CO)

The primary purpose is to house the optical line terminal and ODF (optical distribution frame) as well as provide the required electricity. It's possible that any of the core network's elements are involved.

3.4.3 Feeder -Network

From the optical supply frame (ODF) in the central office (CO) to the supply points, the feeder network region expands. Fiber distribution terminals (FDTs) are the points, which are often street cabinets, where level-1 splitters are normally found. As seen in the diagram above, the feeder cable is usually attached in a ring topology, beginning at one GPON port and terminating at another GPON port.

3.4.4 Distribution- Network's areas

The distribution cable attaches the splitter within the FDT to the fiber access terminals attached to the splitter and is typically housed in a pole mounted box known as a fiber access terminal (FAT) that is naturally located at the neighborhood's door.

3.4.5 User Area

Drop wires are utilized to link the splitters surrounded by the FAT to the user or contributor buildings in this region. An aerial decline cable is usually completed at the entrance hall of the recipient or users' building with a passenger terminal box called (TB), and then an indoor fall cable links the terminal box to an entry terminal box (A-T-B) placed inside the home for ease of maintenance. Finally, the optical terminal network (ONT) is connected to the control terminal box with a patch cable (A-T-B).

GPON technology supports many different transmission line rates for upstream and downstream and see the table below.

Table 3.3: Transmission Bit Rates of GPON

Transmission	Bit Rate
downstream	1.244 Gbps 2.488 Gbps
Upstream	155.52 Mbps 622.08 Mbps 1.244 Gbps 2,488 Gbps

3.5 GPON Transmission and Basic Concepts

The optical line terminal (OLT) is linked to the optical splitter (OS) by a single optical fiber in the GPON network, and the optical splitter is then connected to the optical network terminal (ONT). For data transmission, distinct wavelengths are utilized in upstream and downstream directions. Wavelengths in the upstream direction differ from 1260 nm to 1360 nm, while wavelengths in the downstream direction range from 1480 nm to 1500 nm. The GPON uses wavelength division multiplexing (WDM) to relay data from various upstream and downstream wavelengths over the same ODN. In the downstream direction, data is distributed, and in the upstream direction, data is transmitted in TDMA mode (based on timeslots). The OLT uses the optical network to broadcast all of the facilities to the ONTs. It employs Time Division Multiplexing (TDM) to obtain this result (TDMA). The traffic in the downstream direction is depicted in the diagram.

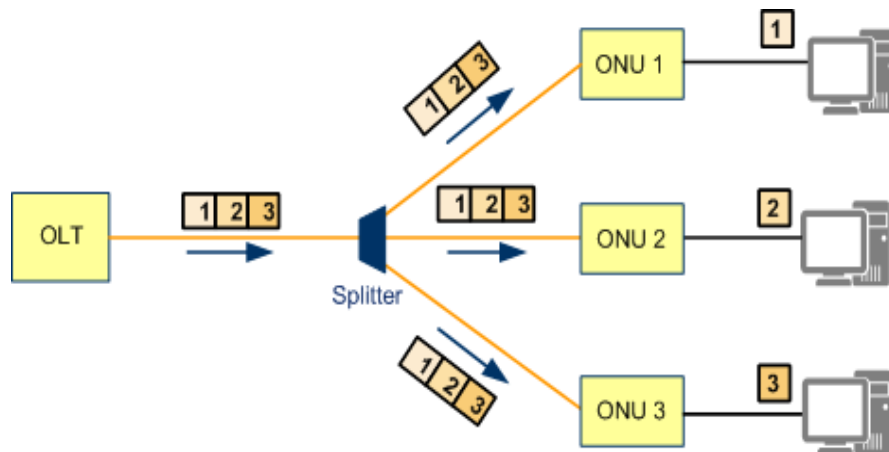

Figure 3.6: traffic in the downstream-direction

Data packages are distributed in the upstream direction using the time division multiple access (TDMA) method. To avoid accidents, each ONT transmits in a specific time slot, and the OLT manages the upload space bandwidth for all ONTs using the dynamic bandwidth allocation (DBA) algorithm . Table 3.4 shows the GPON technology standard specifications.

Table 3.4: GPON Specifications

Parameters	Specification
Standard	ITU_T G.984
Downstream rate	2.488-Gbps
Upstream rate	1.244-Gbps
Downstream wavelength	1490 nm
Upstream wavelength	1310 nm
Protocol	ATM, TDM, Ethernet
Service	Data, Voice, Video
Maximum PON split ratio	1:64
Maximum Distance	20 km

The downstream traffic contains multiple signals committed to ONTs and then broadcast to all clients through the ONTs by the OLT. Every one of the ONTs only receives the packets committed to it and shifts the remaining packets. To achieve this kind of filtering process, OLT uses packet headers for addressing the packets and the ONTs look for these packet addressing data to accept or shift the packets.

3.5.1 Security

The fundamental concept of GPON is that the downstream data is broadcasted to all optical line terminal (ONTs) attached to the GPON. The presence of this structure some users can listen to all the downstream data of all other users. We call this eavesdropping threat which the GPON security system is intended to counter. In ITU-T G984 standard (Satyanarayana Katlay and Abhinov Balagoni, 2013), a security mechanism to prevent the users who are not permitted to access other users' data is described. In addition, the GPON its own has the unique property as it is highly directional. So that any ONT cannot observe the upstream traffic from the other ONTs on the GPON. This allows useful information (such as security keys) to be passed upstream clearly. Although there are

threats that could risk this situation, such as an attacker tapping the common fibers of the GPON, these are considered as not being realistic, since the attacker would have to do so in public spaces and would probably attenuate the GPON he is tapping.

3.5.2 Protection in GPON

The GPON security architecture is thought to improve the access network's stability. While GPON security is regarded as an optional method, its implementation is contingent on the realization of cost-effective programs. There are two major forms of safety switching: automatic switching, which is triggered by fault detection such as signal loss, loss of frame, signal degradation, and so on; and manual switching, which is triggered by fault detection such as signal loss, loss of frame, signal degradation, and so on. Forced switching, on the other hand, is triggered by organizational activities for instance fiber rerouting and fiber substitution.

3.5.3 Encryption System

Each packet transmitted by ONTs will be observed by all the manipulators' member of GPON for the reason of the PON architectures which broadcasts the data to the downstream direction. A security mechanism is defined in the standard which is called Advanced Encryption Standard (AES). The AES is an encryption mechanism which blocks to access to the data field in the GPON frame. The AES mechanism encrypts the data in the data field to an impenetrable form called cipher text and decrypts the cipher text to their original format. It supports keys of 128, 192, and 256 bits, making encryption incredibly difficult to crack. To improve reliability, a key can be updated on a regular basis without disrupting information flow (Xion, 2013).

3.6 Performance Parameters in GPON Network

3.6.1 Error- Rates

The sum of bit errors in the amount of data collected in a contact system as a result of noise, interruption, or modification is described by error rates. The BER (bit error rate) is the ratio of bits that have errors in comparison to the total amount of bits received in a transmission in telecommunications. For example, a bit error rate of (10^{-6}) indicates that one out of every 1,000,000 bits communicated was incorrect. A high bit error rate may indicate that slower data will actually increase the total transmission time for a given quantity of

transmitted data, since the bit error rate determines how much data must be retransmitted due to an error.

3.6.2 Q Factor

Q factor (quality factor) is a suitable measure of global system quality providing when two signals to noise ratio (SNRs) can be united into a single quantity. There are only two imaginable signal stages in binary digital communication structures and respectively of these signal levels may have a diverse regular noise related with it. Which means there are basically two discrete signal-to-noise ratios one is electrical SNR and the other one is optical signal to noise ratio that is related with the two possible signal stages. To compute the total probability of bit error, it should be added into account for both these signals (the signal-to-noise ratios). The figure below shows connection among BER (bit error rate) and the quality factor (Q Factor)

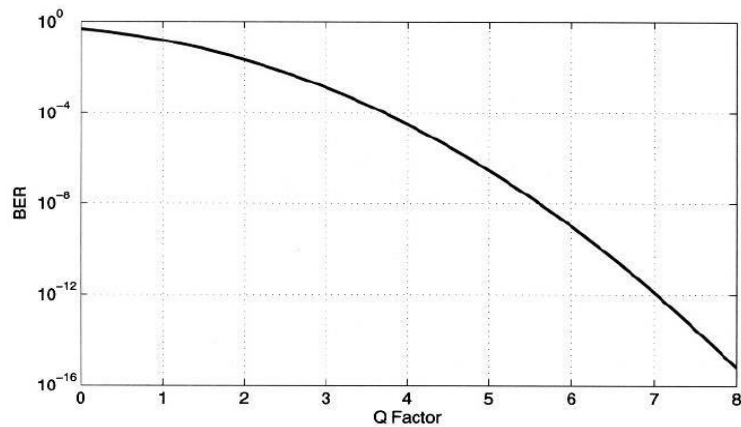

Figure 3.7: BER versus the Q Parament

4. DESIGN OF THE GPON A FTTH ACCESS NETWORK

The most difficult task is designing a fiber to the home (FTTH) network. It necessitates a trade-off between various factors such as expense, scale, and scalability. However, since the practicality of access networks is heavily dependent on user density (subscribers per km² or distance) and settlement systems, there is no common fiberoptic to the home (FTT-H) access system model. As a result, modeling should be based on a concrete settlement system, the defined nation, and the outcomes obtained are dependent on that particular nation (Xion, 2013).

To build the OSP (Outside Plant), desk top preparation is ineffective, instead, each root is physically inspected and then properly designed using skills and practice. Since each country has its own special underground influences, international guidelines cannot be used. The freeze line, also known as the ground thermal line, is a location in the earth's crust where the temperature of the underlying surface stays constant., i.e., it does not freeze or overheat, allowing the FO cable to lie in at a constant temperature. Another critical consideration to consider is the depth and form of backfill content to reduce ground vibration effects. The sequence steps involved in the construction of the fiber to the home (FTTH) network under consideration are summarized in Figure (4.1). In a bottom-up strategy, the architecture begins with the client premises and moves back until it reaches the central office (CO), as seen in Figure 4.7. The key focus of this study is network connectivity, which is needed to offer service such as voice and data, to a sum of 837 subscribers in Afgoye Somalia.

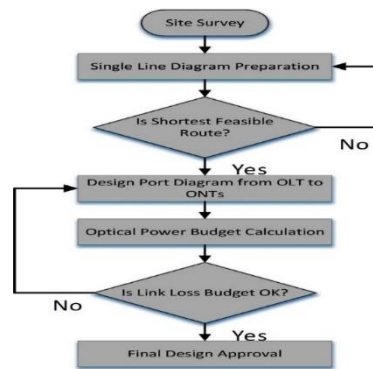

Figure 4.1: GPON FTTH access network design steps

The design of GPON contains the steps involved in the Route survey step, preparing a Single Line diagram, and drawing a port diagram, also splitter allocation design to each route, link loss calculation, (OTDR) Optical Time Domain Reflectometer. This chart shows each step of designing Optical fiber based on GPON the optical power budget and the shortest route the main factors taken into consideration while designing.

Gigabit passive optical network use TDMA which means full-service access requirements.

In general, GPON has one unit called OLT which is service provider for presence it goes to splitter and then it goes to customers. The basic transmission principle of GPON is whatever the OLT sent all the ONT can see. G-PON may be deployed in a variety of ways, including FTTH (where the ONT or ONU is placed inside the home) and FTTB (where the ONU is located in a house, usually in the basement, and copper is used to scatter the surfaces inside the building).

4.1 Optical- fiberoptic parameters

Relevant parameters influence the operation of any transmission device, and it is important to measure and understand these considerations when designing fiber optics. The following are the optical fiber specifications that I will discuss.

4.1.1 Wavelengths

Light that be able to be observed by the naked eye should be labeled as being in the visible range. The color of light can be described as wavelength in the

visible spectrum. To illustrate, the shades of the rainbow like red, yellow, green orange, blue, and violet, all come contained by the detectable spectrum (Figure 4.2). Longer wavelengths, which are transparent to the naked eye, are used in optical fiber communication. For instance, red light has a extended spectrum than blue light, resulting in higher readings. The wavelengths of optical propagation are usually 850 nanometers (nm), 1300 nm, and 1550 nm (et). Light is transmitted via optical fibre using both lasers and light emitting diodes (LEDs). Lasers usually transmit at wavelengths of 850, 1310, and 1550 nm, making them suitable for laser-optimized multimode and single-mode fibers (850 nm) (1310 and 1550 nm). LEDs with wavelengths of 850 or 1300 nm are essential or useful for multimode fiber.

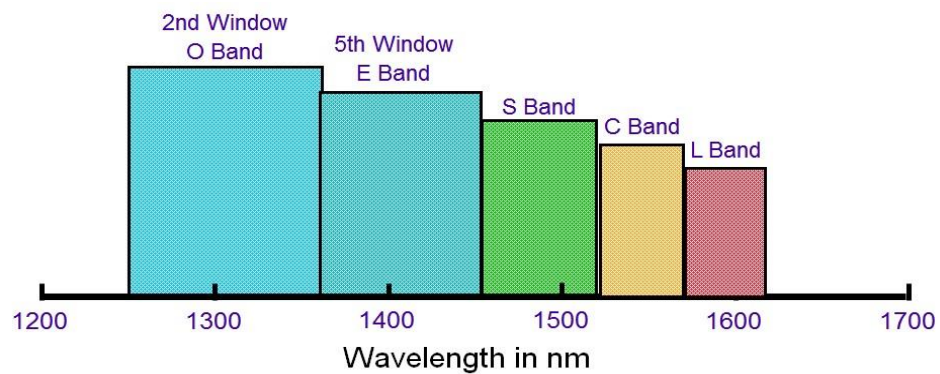

Figure 4.2: Typical optical transmission wave

4.1.2 Frequency

The frequency of a design or structure is the rate of modulation of the light source's digital or analogue emission, or, to put it another way, the number of pulsations per second produced by the light supply (as seen the Figure 4.3). In certain cases, Frequency is expressed in hertz (Hz), with one hertz (1 Hertz) equaling one pulse or loop per second. Megahertz (MHz), or millions of pulses per second, is a further workable measurement for optical networks.

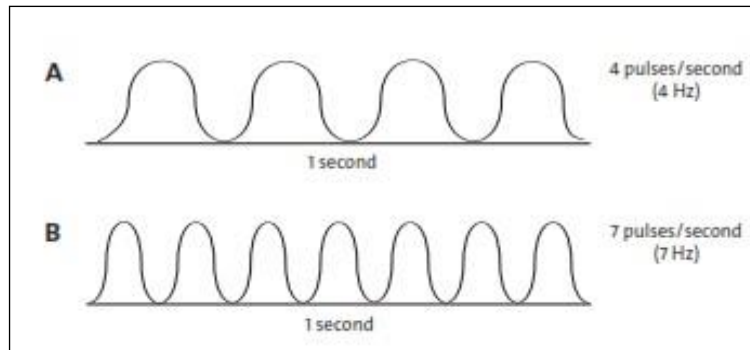

Figure 4.3: Frequency Measurement

4.1.3 Dispersion

The scattering of a light pulse as it flows down a fiber is known as dispersion. The pulses appear to converge as they scatter, or broaden, and the receiver can no longer discriminate between zeros (0s) and ones (1s) (1s). Errors and other information loss occur as light signals are fired close together (high data rates) but spaced out too far (high dispersion).

4.1.3.1 Chromatic dispersion

As a function of the light source's wavelength spectrum, this occurs. LEDs and lasers emit light with a variety of wavelengths. Each wavelength travels at a slightly different distance. The light pulse spreads in time over distance due to the differing wavelength speeds. This is particularly critical in single-mode applications. Since a material's index of refraction is proportional to its wavelength, each frequency variable moves at a slightly different level. If the difference between the two points grows, the pulse gets wider. Only in single-mode fiber is material dispersion an important cause of dispersion (et).

4.1.3.2 Modal dispersion

It only affects multimode fibers and is caused by the modes of light flowing down the fiber arriving at various times at the recipient, creating a spreading effect. The consequences of modal dispersion are mitigated using graded index profiles, which are only used in multimode fibers.

4.1.4 Bandwidth

The overlapping of these light flashes is caused by their scattering. The signals become unreadable by the receiver at a certain distance and frequency. The

various paths of a multimode fiber converge far more than those of a single-mode fiber. Since the lengths of these various paths vary, each mode of light arrives at a distinct time. At one kilometer, device bandwidth is estimated in megahertz (MHz). If the frequency of a device is 20 MHz.km, that ensures that 20 million light pulses per second will pass down 1km (1000m) of fiber, each of which will be different by the receiver.

In my case the bandwidth of the system is 1.64 GHz 1.64 Gbps. Bit rates provide for each users x number of users = 38.875 Mbps x 64 = 2488 Mbps = 2.488 Gbps.

4.2 Small Form Pluggable

small form factor pluggable (SFP) we can define as a Small metal devices optical transceiver module plug compatible used to transmit data from and to a different location in communication networks. Normally small form pluggable (SFP) ports exist in Ethernet hubs, firewall, routers, and LAN cards. In this thesis Source PHOTONICS SPS-43-48H-HP-TDE has been chosen as SFP.

4.3 Fusion Splicing

fusion splicing is the operation fusing and welding two optical fibers to avoid the scattering, reflection and minimizes or decreases insertion loss for the light passing through the fibers. Fusion splicers are capable of splicing cladding diameters up to Ø1.25 mm. there are some Steps to take of Fusion Splicing which are removing the outer materials to expose the bare fiber, clean the fiber glass, cleaving procedure to cut the fiber to make it smooth and reduce cleaving defects by avoiding cut off scattering Reinforcing splice with the protection of sleeve by using heat.

4.4 Connectors

An optical fiber connector is a flexible device that connects fiber optic cables that need quick or disconnection. There are many different optical connectors, but it can be differentiated by looking mechanical coupling technique and dimensions, optical fiber connectors make certain of providing a stable

connection they also ensure the fiber ends optically smooth and the end to end possession to probably aligned. An optical fiber connector is also called fiber optic connector. Two of the most

common fiber connectors in single mode are Subscriber connector (SC) and Lucent (LC). The figure 4.4 shows the connector diagram of the project.

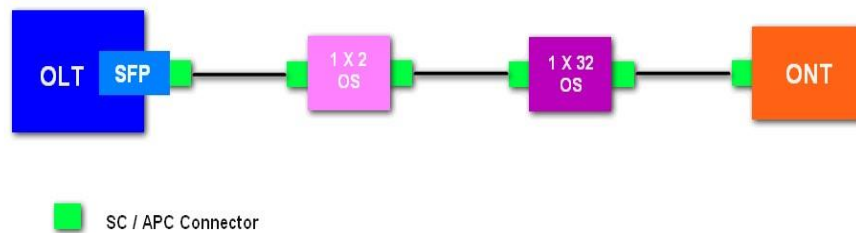

Figure 4.4: connector block diagram

4.5 Home Gateway

A home gateway (HGW) is an IP address of a router or a system that links several computers to a cable or DSL line for internet access. It's known as a modem or router. It includes a modem for cable or DSL operation, an Ethernet switch for connecting computers via router and wire, and a Wireless Fidelity access point. TILGIN HG1330 HGWs have been chosen for this study or analysis. In more understandable way, a gateway is a network node that links two networks using separate protocols. It often serves as a gate between two distinct devices, such as a router, firewall, server, or other system that allows traffic to flow in and out of the networks.

4.6 Calculation and Design Validation

Step 1: Calculation of total link length

Link length between telecom main hub and block which has the longest F/O distance as shown on the Figure 4. 6 is 1049 m

After adding 100 m F/O cable which is the distance between basement of building to top floor, sum of the link length will be as below.

$$1049 \text{ m} + 100 \text{ m} = 1149 \text{ m}$$

Total link length: 1.149 km.

Step 2: Calculation of bit rate provide for each user

$$\frac{\text{SFP Downstream}}{\text{Number Of FTTH user in SFP}} = \frac{2488\text{Mbps}}{64} = 38.875\text{Mbps} \quad (4.1)$$

The bit rate committed to the subscribers will be 25 Mbps, as the calculated amount is 38.875 Mbps, this can be easily configurable and realizable.

Step 3: Calculation of total required link

Bit rate provide for each user x number of users

38.875 Mbps x 837 = 32.6 Gbps. %10 Add to total required link as margin to guarantee the service

$$32.6 \text{ Gbps} + \%10 = 35.86 \text{ Gbps}$$

Step 5: Calculation of total number of SFP needed in this Project.

$$\frac{\text{Number of users*Bit rate provided for each user}}{\text{SFP downstream}} = 13.08 \quad (4.2)$$

So that the total number of SFP needed in this project is 14

Step 6: Calculation of total number of GP8 boards needed on OLT.

Number of SFP needed in this project is calculated as 14. Each GP8 board can have maximum 8 SFPs.

So that we can calculate the total number of GP8 boards needed in this project as follows

$$\frac{\text{Total number of SFP}}{8} = \frac{14}{8} = 1.75 \quad (4.3)$$

4 GP8 boards are needed.

Step 7: Calculation of chromatic dispersion coefficient of F/O

The chromatic dispersion of a fiber is defined as the relative arrival delay (in ps) of two wavelength components separated by one nanometer (nm).

$$\frac{\Lambda * S_{0\text{max}}}{4} * \left(1 - \left(\frac{\lambda_{0\text{max}}}{\lambda}\right)^4\right) \leq D(\lambda)$$

$$\leq \frac{\lambda * S_{0max}}{4} * \left(1 - \left(\frac{\lambda_{0min}}{\lambda}\right)^4\right) \quad (4.4)$$

Where

D: Chromatic dispersion coefficient of F/O

$\lambda = 1490 \text{ nm}$ (SFP, TX) (from data sheet of SFP)

$\lambda_{0min} = 1300 \text{ nm}$ (from data sheet of ITU-T G652D)

$\lambda_{0max} = 1324 \text{ nm}$ (from data sheet of ITU-T G652D)

$S_{0max} = 0.092 \text{ ps/nm}^2 \times \text{km}$ (from data sheet of ITU-T G652D)

$$12.904 \frac{\text{ps}}{\text{nm} * \text{km}} \leq D(1490 \text{ nm}) \leq 14.411 \frac{\text{ps}}{\text{nm} * \text{km}}$$

$$\frac{12.904 + 14.411}{2} = 13.7 \frac{\text{ps}}{\text{nm} * \text{km}}$$

$$D = 13.7 \frac{\text{ps}}{\text{nm} * \text{km}}$$

Step 8: Calculation of dispersion

$$ds = D * S * L \quad (4.5)$$

Where?

D: Chromatic dispersion coefficient of F/O

S: spectral-width of the light source

L: length of the F/O

$$ds = 13.7 \frac{\text{ps}}{\text{nm} * \text{km}} * 1 \text{ nm} * 1.149 \text{ km} = 15.7 \text{ Ps}$$

Step 9: Calculation of F/O bandwidth

$$B_{F/O} = \frac{0.44}{ds}$$

$$B_{F/O} = \frac{0.44}{15.7 \text{ ps}} = 28 \text{ GHz}$$

Step 10: Calculation of F/O rise time

$$tr_{F/O} = \frac{0.35}{B_{F/O}} = \frac{0.35}{28 \text{ GHz}} = 12.5 \text{ ps}$$

Step 11: Calculation of transmitter rise time.

$tr_{TX} = 160 \text{ ps}$ (see data sheet of SFP)

Step 12: Calculation of receiver rise time.

Downstream is 2488 Mbps (see data sheet of ONT)

In practical life the bit rate we will use for transmission will be the same as the bandwidth of this channel. Therefore, bandwidth of the ONT is 2.488 GHz.

$$tr_{RX} = \frac{0.35}{B_{ONT}} = \frac{0.35}{2.488 * 10^9} = 141ps$$

B_{ONT} =Bandwidth of ONTR

Step 13: Calculation of system rise time.

$$tr_{SYS} = \sqrt{tr_{TX}^2 + tr_{F/O}^2 + tr_{RX}^2} = \sqrt{(160ps)^2 + (12.5ps)^2 + (141ps)^2}$$

$$T_{x_{SYS}} = 214ps$$

Step 14: Calculation of system bandwidth

$$B_{SYS} = \frac{0.35}{tr_{SYS}} = \frac{0.35}{214ps} = 1.6 \text{ GHZ}$$

$$1.6 \text{ GHZ} = 1.6 \text{ Gbps}$$

Total bit rate provided for all users is given by Bit rate provide for each users x number of users = 38.875 Mbps x 64 = 2488 Mbps = 2.488 Gbps. It has been understood that the number of bits provided by the system did not meet the requirements obtained by the calculations given above. But in the below calculation, we can see that there will not be any slowing down in the system if internet usage of the apartments doesn't exceed ratio %66 of the system capacity.

$$\frac{1.6 \text{ Gbps}}{2.448 \text{ Gbps}} = 0.66$$

Even if ratio of use exceeds %66, slowing down in the system will be tolerated by the subscribers since committed bit rate is 25 Mbps.

Step 15: Calculation of link budget

$$LB = P_{TX} - P_{RX}$$

Where

PTX: Transmitter power

PRX: Receiver power

$$P_{TX} = 5dBm \text{ (see data sheet of SFP)}$$

$$P_{RX} = -28dBm \text{ (see the datasheet of ONT)}$$

$$LB = 5dBm - 28dBm = 33dBm$$

Step 16: loss calculations

$$\text{Aging loss} = 1dB$$

$$\text{Repairing loss} = 0.2dB$$

$$\text{Security loss} = 2 dB$$

$$F/O \text{ cable loss} = 0.25dB/km = 0.25dB/km * 1.149km = 0.29dB$$

$$\text{fusion splice loss} = 0.1dB * 4 = 0.4 dB$$

$$\begin{aligned} \text{connector loss} &= 0.4dB * 1 = 0.4 dB \\ 1 \times 2 \text{ optical splitter insertion loss} & \\ &= 4.6dB \end{aligned}$$

$$1 \times 32 \text{ optical splitter insertion loss} = 17.6dB$$

$$\begin{aligned} \text{Total loss in the link} &= 1dB + 0.2dB + 2dB + 0.29dB + 0.4dB + 0.4dB + \\ &4.6dB + 17.6dB = 26.49dB \end{aligned}$$

As calculated link budget 33 dBm higher than total loss in the link the system is realizable.

4.7 Cost Calculations Of The Project

Table 4.1: Calculation of the cost of the project

Item No	Description	Quantity	Unit Price	Currency	Total price
1	6 F/O (outdoor)	702 m	0.29\$	USD	\$203.58
2	4 F/O (outdoor)	265 m	0.27 \$	USD	\$71.55
3	1 F/O (indoor)	23500 m	0.11 \$	USD	\$2585
4	1X2 OS (includes two SC/APC connected pairs)	17 pcs	10 \$	USD	\$170
5	1X32 OS (includes two SC/APC connector pairs)	31 pcs	13 \$	USD	\$403
6	ONT	837 pcs	10 \$	USD	\$8370
7	HGW	837 pcs	8\$	USD	\$6696
8	SC/APC connector	837 pcs	1.85 \$	USD	\$1548.45
Material costs					\$10,000
Labour costs					\$3000
Financial costs					\$2500
Project expenses					\$1500
Profit					\$8000
Total costs					\$45047.58

4.8 Location and Selection

The goal of this thesis is to design a FTTH network in a developing city in Afgoye, Somalia by using GPON technology to provide faster and more reliable data transmission. After making a very careful survey the map of the project is shown the figure 4.5 Project area map are shown below



Figure 4.5: Afgoye project area map

The table 4.2 explains the details of the project such number of user and block names for each block I divided into 4 blocks each of these blocks has specific number of users and transmission bit rate. In total the number of users for this project is 837

Table 4.2: project information and number of users

Project address	Afgoye city Somalia
Number of Buildings	4
Block Names	A, B1, B2, C blocks
Number of FTTH Users in A Block	257
Number of FTTH Users in B1 Block	255
Number of FTTH Users in B2 Blocks	256
Number of FTTH Users in C Blocks	69
The Total Number of FTTH users-Users in This Project	837

4.9 Design, Simulations, Results and Distribution Network

The figure 4.6 shows the distribution network connected to telecom main hub and ends customer premises, as a result, the above-mentioned architecture protocol is adopted in the design of the project's entire delivery network. Three fiber optic distribution cables are attached to manhole one. The number written the line entering manholes refers to the fiber optic cables deployed, for example, (01-144) refers to the first cable. The fiber access terminals (FATs)

are depicted in the design as ellipses. For FATs, digit counting is used as the terminology. The first digit from the left indicates the number of fiber optic cables installed, while the last digit indicates the delivery cable series number. For This terminology operates uniformly to delivery systems linked all additional fiber distribution. For instance, the Figure 4.6, fiber access terminal number 01-144 is a Fiber cable in the first distribution cable of manhole. Design, administration, monitoring, and eventual extension are all made simpler with this language. A pre-defined sequence of steps must be followed when carrying out an engineering project. This is especially important in projects with a combination of engineering actions, where a mistake at one stage will cause errors to propagate to subsequent stages. Fiber to the home (FTTH) schemes are an example of this, since they combine civil and engineering works. The Design operation planning saves time, cost, and effort. As a result, this topic is given careful thought. Figure 4.7 depicts the key actions taken in this project and their order. Fiber optics (FO) testing is given special attention at the end of each stage. When the cable jacket is not clearly affected, two approaches are agreed Controlling the exact location of a split optical fiber in an existing optical fiber cable is the aim of this project. OTDR monitoring and a laser source or power meter collection are examples. For attenuation testing and fault position in the feeder network, an optical time domain reflectometer (OTDR) is used, while other measurements are performed using a laser source or a power meter.

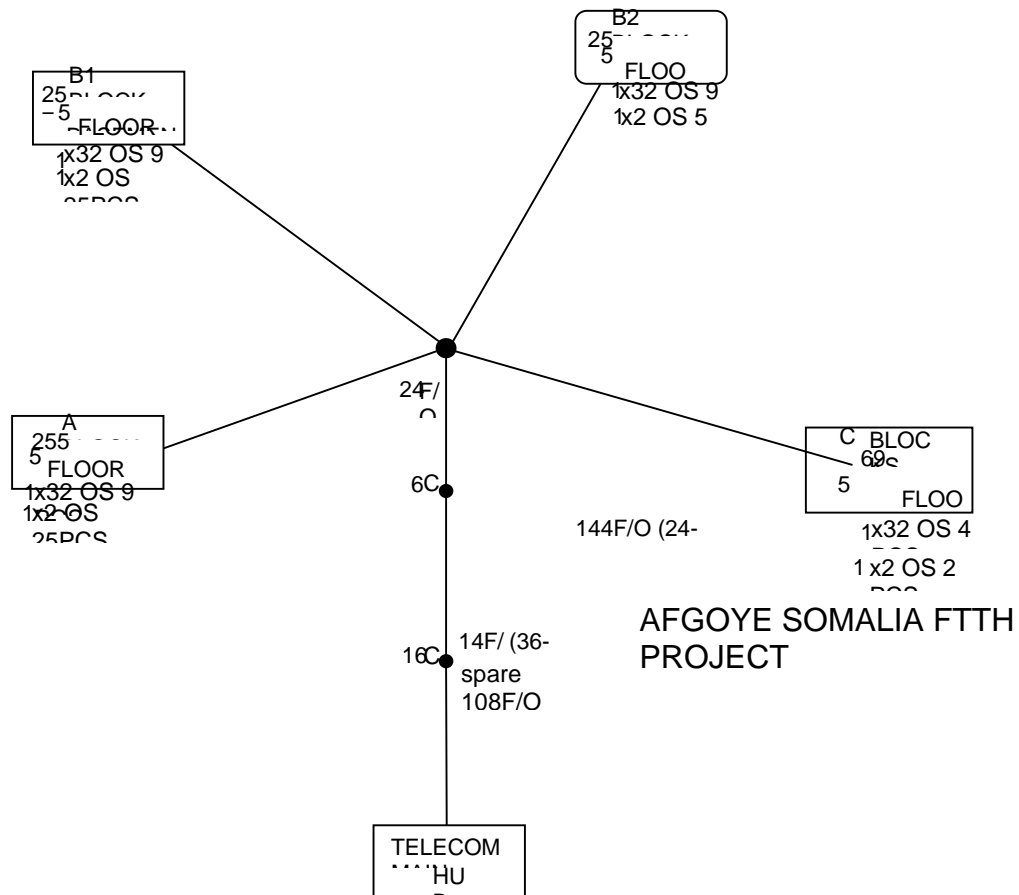

Figure 4.6: design and distribution network of the project

The 2.5 Gbps simulation design of GPON is performed in Opti system software. The model is created for a single user situation. It contains of NRZ pulse generator, pseudo random sequence generator, MachZehnder modulator, nonstop wave laser source, it is also have an ONT receiver part which have photodiode_low pass filter_3R generator_BER analyzer and optical fiber filter. The connection, occasionally known as network, is contains of 20 km of optical attenuator and single mode fiber .

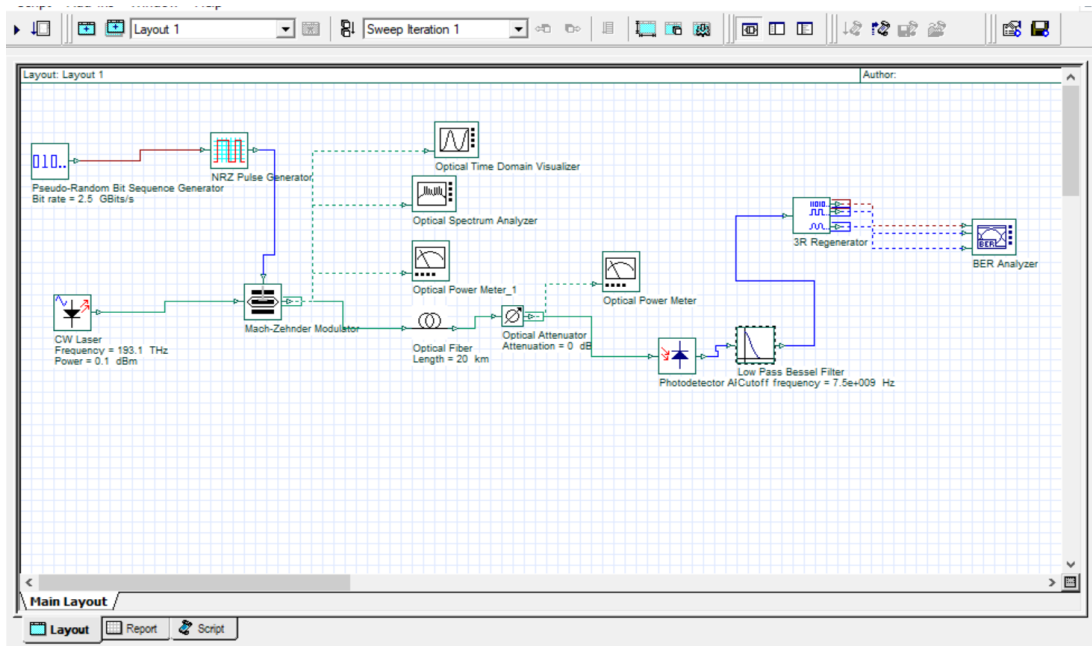

Figure 4.7: Downstream GPON simulation in Opti-system for Single User

1490 and 1300 nm wavelength is selected with a fibre length of 20-km and the fibre attenuation.

Table 4.3: Result table

Q factor	25.2437
Min BER	2.5179e-201
Optical power	Before transmission -4.5dB After transmission -8.5dB

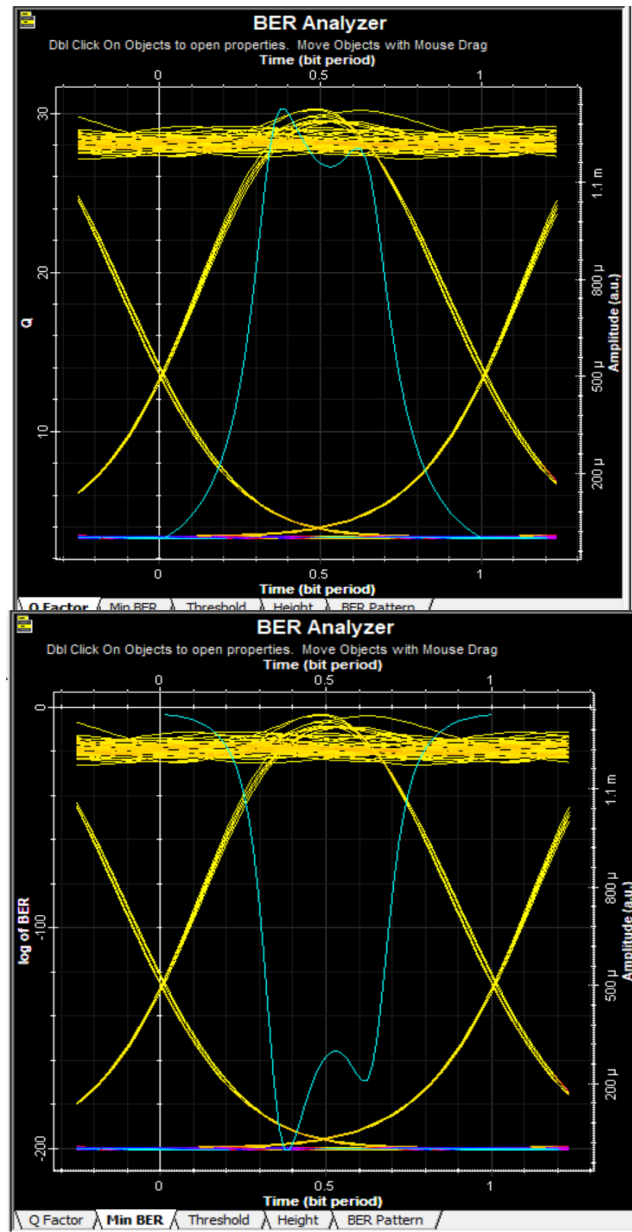

Figure 4.8: Q Factor

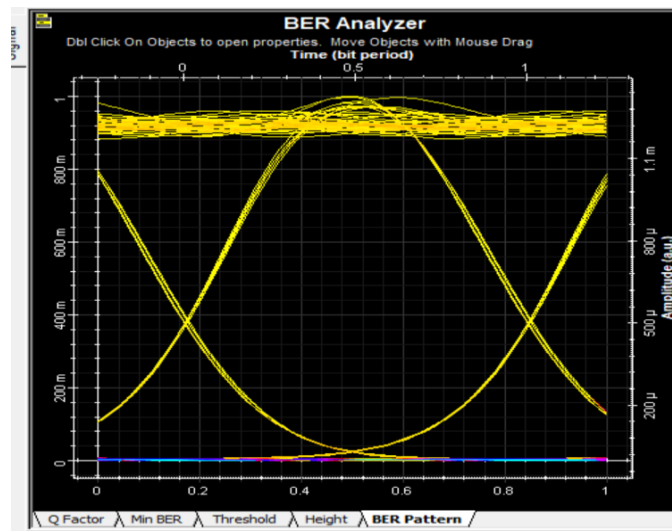
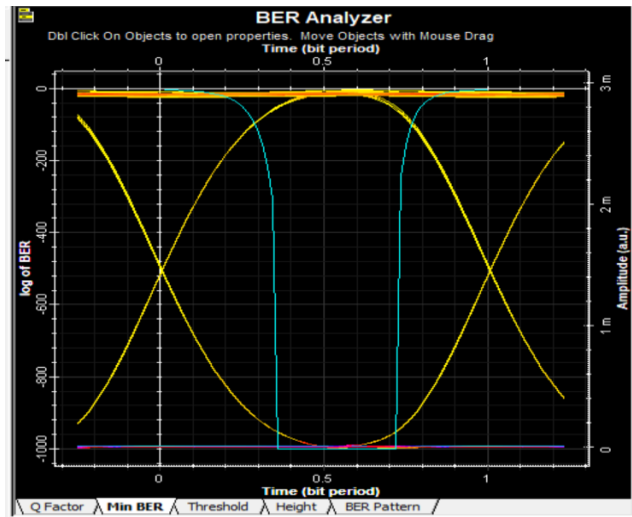

Figure 4.9: Min. BER

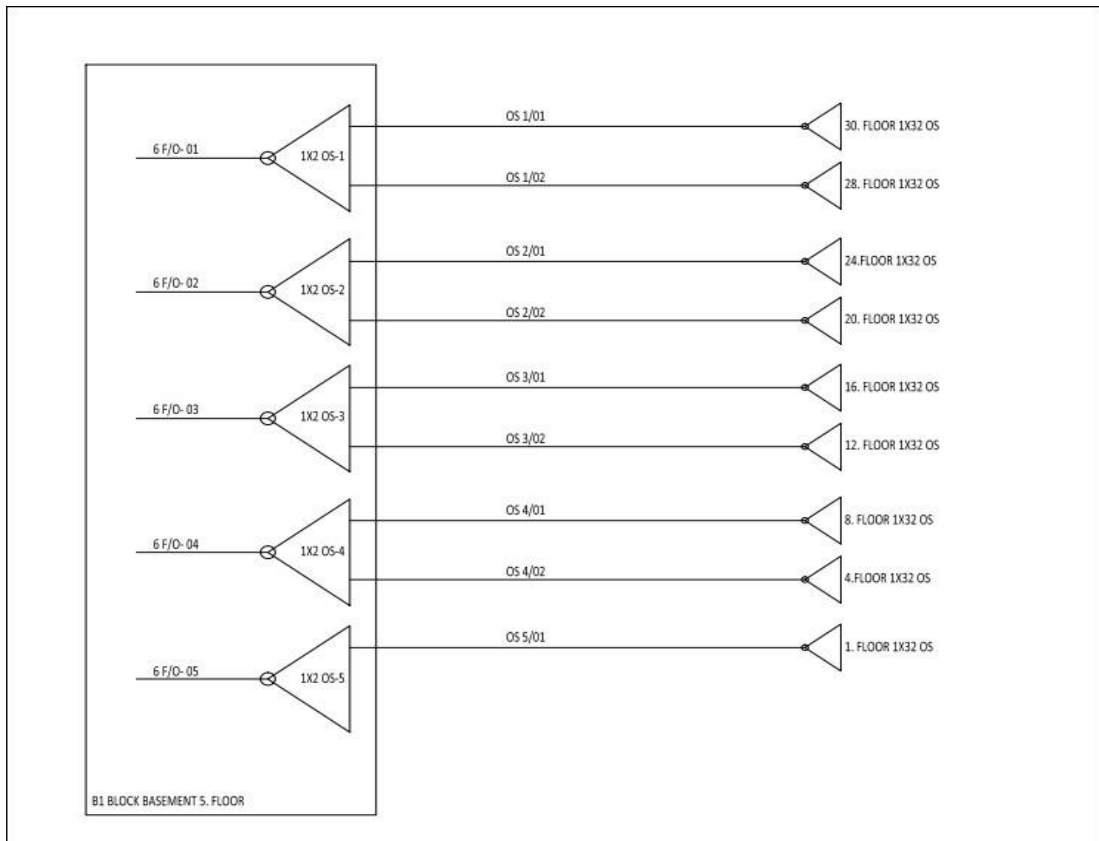

Figure 4.10: Eye Diagram and it

contains 30 floors each floor needs a separate splitter to deploy the fiber. The total number of splitters in this block is 11 optical splitter and the numbers written there tells the sequence of the splitter for example 6F/O-01. Fiber optic splitters are used if a network's light beam has to be separated into at least two laser. The light energy cannot completely focus in the fiber center while a single_mode fiber is used to relay a light signal. The cladding of the fiber will spread a tiny amount of energy. The transmitting light in one optical fiber will penetrate another optical fiber if they are close enough together. Consequently, optical signal reallocation can be done in several fibers. This is how a fiber optic splitter is made. The splitter neither generates power nor consumes electricity. Therefore, splitter do not need any electronic components and also splitter is a passive equipment. In short optical splitters can be called beam splitter.

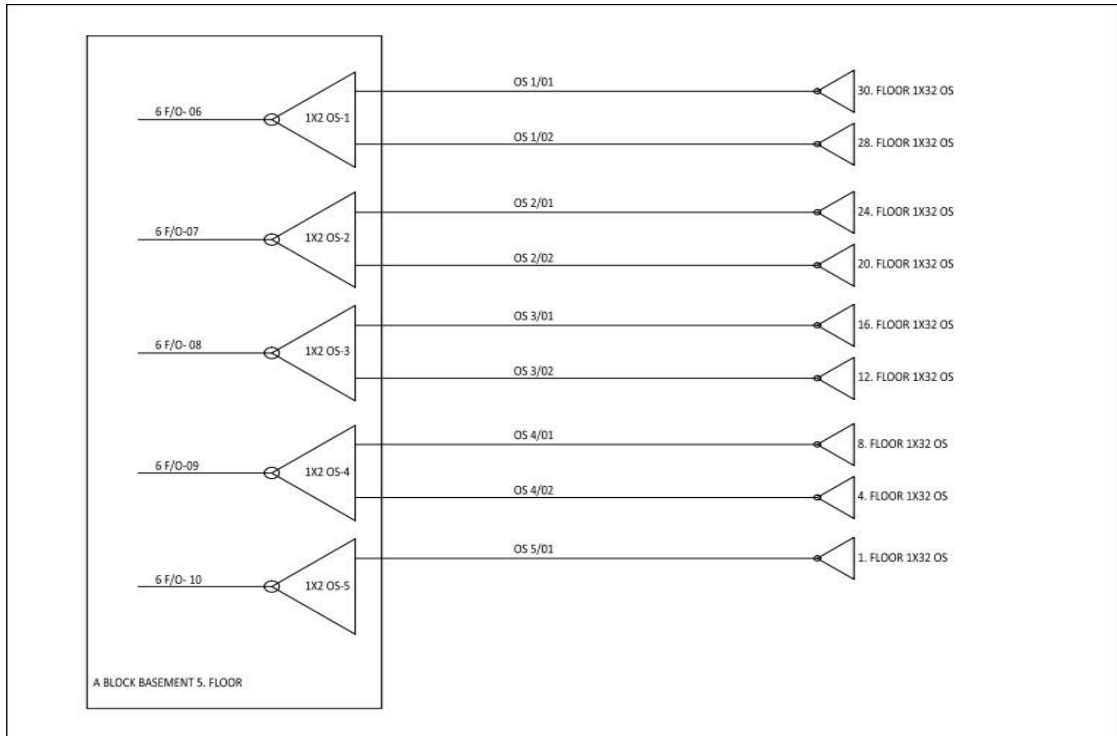

Figure 4.11: A blocks Splitter Block Diagram

The figure 4.11 shows that the deployment of optical fiber splitter in A block and it contains 30 floors each floor needs a separate splitter to deploy the fiber. The total number of splitters in this block is 14 optical splitter and the numbers written there tells the sequence of the splitter for example 6F/O-06. Fiber optic splitters are used if a network's light beam has to be separated into at least two laser. The light energy cannot completely focus in the fiber center while a single_mode fiber is used to relay a light signal. The cladding of the fiber will spread a tiny amount of energy. The transmitting light in one optical fiber will penetrate another optical fiber if they are close enough together. Consequently, optical signal reallocation can be done in several fibers. This is how a fiber optic splitter is made. The splitter neither generates power nor consumes electricity. Therefore, splitter do not need any electronic components and also splitter is a passive equipment .in short optical splitters can be called beam splitter.

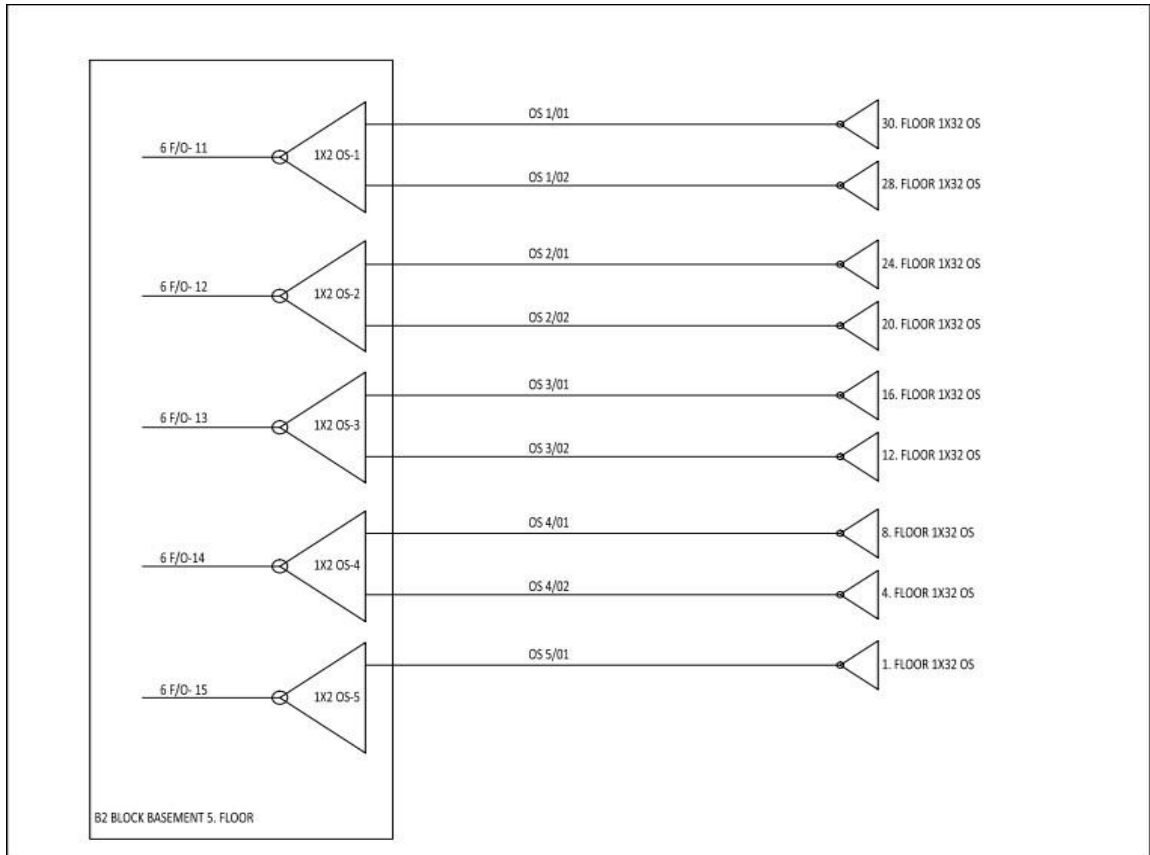

Figure 4.12: B2 blocks Splitter Block Diagram

The figure 4.12 shows that the deployment of optical fiber splitter in B2 block and it contains 30 floors each floor needs a separate splitter to deploy the fiber. The total number of splitters in this block is 14 optical splitter and the numbers written there tells the sequence of the splitter for example 6F/O-11. Fiber optic splitters are used if a network's light beam has to be separated into at least two lasers. The light energy cannot completely focus in the fiber center while a single-mode fiber is used to relay a light signal. The cladding of the fiber will spread a tiny amount of energy. The transmitting light in one optical fiber will penetrate another optical fiber if they are close enough together. Consequently, optical signal reallocation can be done in several fibers. This is how a fiber optic splitter is made. The splitter neither generates power nor consumes electricity. Therefore, splitter do not need any electronic components and also splitter is a passive equipment .in short optical splitters can be called beam splitter.

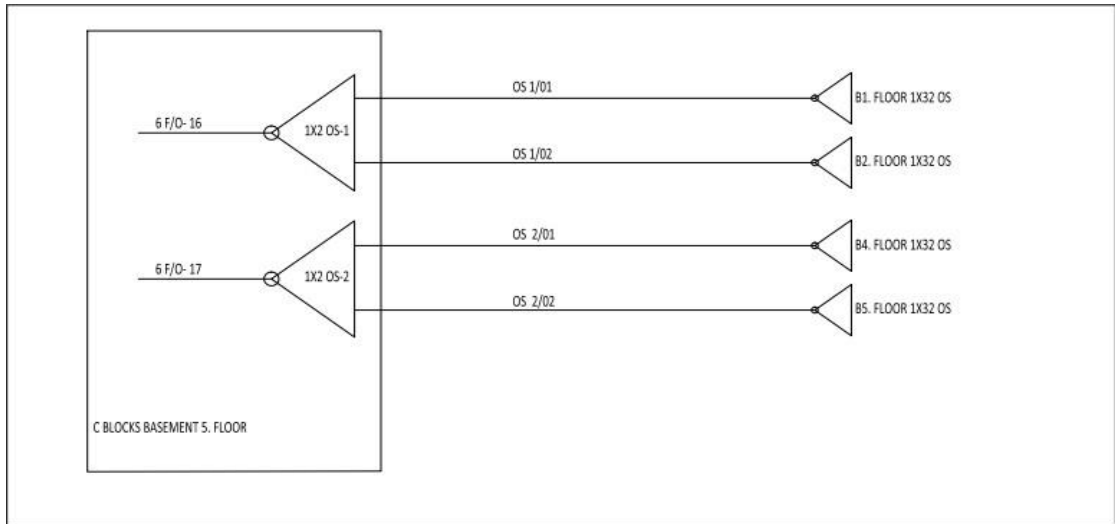

Figure 4.13: C blocks Splitter Block Diagram

The figure 4.13 shows that the deployment of optical fiber splitter in C block and it contains 30 floors each floor needs a separate splitter to deploy the fiber. The total number of splitters in this block is 6 optical splitter and the numbers written there tells the sequence of the splitter for example 6F/O-16. Fiber optic splitters are used if a network's light beam has to be separated into at least two laser. The light energy cannot completely focus in the fiber center while a single-mode fiber is used to relay a light signal. The cladding of the fiber will spread a tiny amount of energy. The transmitting light in one optical fiber will penetrate another optical fiber if they are close enough together. Consequently, optical signal reallocation can be done in several fibers. This is how a fiber optic splitter is made. The splitter neither generates power nor consumes electricity. Therefore, splitter do not need any electronic components and also splitter is a passive equipment .in short optical splitters can be called beam splitter.

5. CONCLUSION

This thesis provides a general concept of a GPON-based FTTH gain access to system serving 837 subscribers, emphasizing functional considerations and field knowledge with an engineering mindset. The architecture procedure favored a bottom side up approach, where the network's scope and elements are well-defined by evaluating the parameters, the number of sites, available resources, and geographical division. The spatial survey of each root must be used to construct the OSP. The optical power budgets for distant areas are measured to assess the design's validity. The design measures and monitoring methods are discussed, and the design map summarizes these steps. The approval of the process introduced in this research has avoided a lot of works, budget and it made project speedy up. In this thesis, fiber optic infrastructure has been applied on new buildings in Afgoye Somalia region by using GPON technology. Since the buildings in this region appeal to high-speed network, high speed internet service should be provided. Therefore, FTTH system that starts from Telecom main hub and goes until the apartments of end users has been chosen. Fiber optic system is a wideband internet which is a product of recent technology and requires low cost for maintenance compared to copper wire. By this Project which aimed to make this system accessible to end users. The speed rate is given is 38.875 Mbps bit rate by an investment cost of \$45047.58. A configurable structure was set up for higher internet speed on based on customers' demand. To increase speed of internet just increasing number of GP8 boards and SFPs in the Telecom main hub will be enough. To increase device lifetime SC/APC connectors which produced with 8° angle have been chosen. Therefore, back reflection of light and resulting device damage will be avoided.

REFERENCES

- Rajneesh Kalera and R.S. Kalerb**, “Simulation of Fiber to the Home at 10 Gbit/s using GE-PON architecture,” *Optik: Elsevier B.V*, pp. 1362-1366, 2011.
- Salah Al-Chalabi**, “Optically Powered Telephone System over Optical Fiber with High Service Availability and Low Risk of Investment in FTTH Infrastructure,” *IEEE Communications Magazine*, August 2012.
- Jagjit Singh Malhotra, Manoj Kumar and Ajay K. Sharma**, “Low cost solution to high capacity 32×32 channel FTTH duplex link employing triple play services,” *Optik: Elsevier B.V*, pp. 93-96, 2014.
- Juan Rendon Schneir and Yupeng Xiong**, “Economic implications of a co-investment scheme for FTTH/PON architectures,” *Telecommunications Policy: Elsevier B.V*, pp. 849-860. 2013.
- Dirk Breuer et al.**, “Opportunities for Next-Generation Optical Access,” *IEEE Communications Magazine*, February 2011.
- Juan Rendon Schneir and Yupeng Xiong**, “Economic implications of a co-investment scheme for FTTH/PON architectures,” *Telecommunications Policy: Elsevier B.V*, pp. 849-860. 2013.
- Jani Saheb Shaik**, “FTTH deployment options for telecom operators,” www.sterlitetechnologies.com.
- Lin. Chinlon**, "Broadband Optical Access Networks and Fiber-to-theHome", wiley, 2006.
- Keiser, Gerd (2006)**. *FTTX concepts and applications*. John Wiley & Sons, Inc..
- Rong Zhao et al.**, “Dynamic Migration Planning towards FTTH,” in proc. IEEE 2010 9th Conference of Telecommunication, Media and Internet, pp.1-6, 2010.
- Steffen Hoernig et al.**, “The impact of different fiber access network technologies on cost, competition and welfare,” *Telecommunications Policy: Elsevier B.V*, 2012, pp. 96-112
- Concept to Design** Electronic Intelligence Framework for Support E-Government Iraq as Case Study”, *Advances in Computing*, 4 (1), 22-24, 2014.
- J. Shaik**, “FTTH Deployment Options for Telecom Operators, Sterlite Optical Technologies” Ltd
- IV.SHUMATE, P. W. (2008)**, Fiber-to-the-Home: 1977–2007, *JOURNAL OF LIG*

Deeksha Kocher et al., "Simulation of fiber to the home triple play services at 2 Gbit/s using GE-PON architecture for 56 ONUs," *Optik*: Elsevier B.V, pp. 5007-5010, 2013.

J J.CHEN, "Design, Analysis and Simulation of Optical Access and Wide-area Networks

Frank Effenberger et al., "An Introduction to PON Technologies," *IEEE Communications Magazine*, March 2007, pp. 517-525.

ITU-T RECOMMENDATION G.984.1, (GPON)

C. a. A. Salihovic, "Gigabit Passive Optical Network-GPON," pp.679 684, 2007.

M. R. A. G. H. a. M. Z. M. S. M. Jahangir Alam, "Bit Error Rate Optimization in Fiber Optic Communications," *International Journal of Machine Learning and Computing*, Vol.1, no.5, December, 2011

Prof. Eng. Miloslav Filka, CSc., *Transmission Media*, Brno April 2009, ISBN 978-80- 86785-15-8

ÖZ GEÇMİŞ